

EVVO Series String Inverter (60K) User Manual

Version: V1.1

Thank you for purchasing products developed and manufactured by EVOLVE ENERGY GROUP Co., Ltd. (hereinafter referred to as “EVOLVE ENERGY GROUP”). We hope our products and this manual can meet your demands. Any suggestion for improvement shall be highly appreciated. EVOLVE ENERGY GROUP Co., Ltd. reserves the copyright of this manual, and it shall be subject to change without any further notice.

About this manual



For Readers

This manual is helpful for technicians who install, debug, operate and maintain string inverters of EVOLVE ENERGY GROUP. Please read this manual carefully before operates the product. Readers are required to know the basic knowledge about electric components, wiring, signs and mechanical drawings.

Outlines

Chapter	Contents
1 Safety Precautions	This chapter describes the safety precautions when transporting, storing, installing, running and maintaining the Inverter.
2 Product Description	This chapter describes the basic principles, naming rules, product configuration and data.
3 System Installation	This chapter describes the unpacking inspection, installation tools, installation environment, reserved space, fixing method, cable connection.
4 Commissioning Guide	This chapter describes the inspection before startup, commissioning and startup of string inverter.
5 Maintenance and Troubleshooting	This chapter describes the daily maintenance methods, maintenance intervals and troubleshooting of the product.
6 Inverter Handling Guide	This chapter describes the basic requirements and precautions when disassembling, replacing, and scrapping the inverter.

Warning Signs in This Manual

 DANGER	Major potential danger (especially refer to high voltage danger). Failure to observe the rules might cause severe personal injury or property loss.
 WARNING	Ordinary potential danger. Failure to observe the rules might cause personal injury or property loss.
 CAUTION	Ordinary potential danger. Failure to observe the rules might cause malfunction of the equipment or property loss.

Glossaries and Abbreviations

Glossaries/Abbreviations	Description
MPPT	Maximum power point tracking
Photovoltaic string	Multiple solar cell arrays in parallel or series
EEPROM	Electrically erasable programmable read-only memory

Contents

1 Safety Precautions	1
1.1 Transport	1
1.2 Storage	1
1.3 Installation	2
1.4 Operating	2
1.5 Maintenance	3
2 Product Description	5
2.1 Product Introduction	5
2.1.1 Schematic Diagram	5
2.1.2 Operating Mode	5
2.2 System Configuration and Application	6
2.2.1 Application Description	6
2.2.2 Supported Grid Form	7
2.3 Naming Rules	7
2.4 Nameplate Label	8
2.5 Inverter Configuration	9
2.6 Labels on the Package	10
2.7 Warning Signs on the Inverter	11
2.8 Technical Data	12
2.9 Mechanical Parameters	13
2.10 Ambient Requirements	14
3 System Installation	15
3.1 Unpack and Inspect	15
3.2 Installation Tool Preparation	15
3.3 Installation Environment Requirements	15
3.4 Reserved Space Requirement	16
3.5 Installation Method	17
3.5.1 Hoop Mounting	17
3.5.2 Screw Rod Mounting	17
3.5.3 Wall/Bracket Mounting	18
3.6 Electrical Connections	19
3.6.1 Cable Requirements	19
3.6.2 Cable Selection	20
3.6.3 Torque Requirement	20
3.6.4 Preparation before Operation	21
3.6.5 Connect the Ground Wire	21
3.6.6 Open the Lower Door Panel	22
3.6.7 Connect the AC Output Cable	22
3.6.8 Connect Communication Cable	23
3.6.9 Connect the DC Input Cable	23
4 Commissioning Guide	27
4.1 Check before Power On	27
4.2 System Power On	27
4.3 System Power Off	27
5 Maintenance and Troubleshooting	29
5.1 Maintenance Items and Cycles	29
5.2 Troubleshooting	30

6 Inverter Handling Guide	35
6.1 Disassemble the Inverter.....	35
6.2 Replace the Inverter.....	35
6.3 Package the Inverter	35
6.4 Scrap the Inverter.....	35

1 Safety Precautions

In this chapter, it describes the safety precautions that must be observed when installing, operating and maintaining the inverter. Please read them carefully before operation and follow them in operation process; otherwise it might cause damage to the inverter, the generator and related equipments or cause serious injury or loss of life.

When you use and operate the inverter, please take special attention to:



1. Only the qualified personnel are allowed to install, operate and maintain the inverters.
2. Do NOT incline or collide the product in transportation.
3. Do NOT make any liquid, sundries or rubbishes enter inside as they might cause short circuit inside the inverter.
4. Inverter must be disconnected with AC grid before completion of installation and maintenance.
5. Related protective measures are required to avoid electric shock or fire accident.



Please do not place inflammables and explosives around the inverter to ensure environmental safety.

1.1 Transport



1. When transporting, it is necessary to ensure that the inverter is packaged properly and the cabinet is fixed upwards to avoid strong vibration and collision.
2. In order to keep the inverter in good condition during transportation, it is important to use packaged transport and operate according to the labels on the package. For the meaning of the logos, please refer to [2.6 Signs on Package](#).
3. The transportation environment must meet the requirements. Please refer to [2.10 Ambient Requirements](#).

1.2 Storage



The storage environment of the string inverter must meet the corresponding requirements. Please refer to [2.10 Ambient Requirements](#).

About long-term storage:

Before or after the installation and commissioning, if the string inverter is in the no-power supply state for more than three weeks, it is regarded as long-term storage. Long-term storage of string inverters requires attention to the following issues:

- Put the desiccant into the cabinet and package the whole machine with packaging materials.
- When storing equipment, pay attention to ventilation and moisture. Stagnant water is strictly forbidden in the storage environment.
- Pay attention to the harsh environment, such as quenching, sudden heat, collision, dust, etc., to avoid damage to the string inverter.
- Regular inspections are required, usually not less than once a week. Check whether the packaging is intact to avoid pest bites. If it is damaged, it needs to be replaced immediately.
- If the storage time exceeds half a year, the package should be opened for inspection, repackaged, and desiccant replaced.
- It is strictly forbidden to store the device without packaging.

1.3 Installation



1. Before operating the internals of the string inverter, it must be confirmed that the input switch DC Switch of the string inverter and the circuit breaker corresponding to the AC side of the inverter are in the off state, and the housing of the inverter is reliably guaranteed.
2. The string inverter must be grounded according to the specifications. The size of the grounding conductor must meet the requirements of safety regulations to ensure the safety of personnel.



1. During installation, it is necessary to ensure that the string inverter's installation environment is well ventilated and heat-dissipating, and the device should not be directly exposed to sunlight.
2. The fixing of the string inverter is recommended by two people working together to avoid mechanical damage. During the installation process, safety measures should be taken to prevent bruises.
3. During installation and maintenance, it is necessary to prevent liquid, dust or debris from entering the inside of the string inverter. Conductive liquids and debris may cause internal short circuit of the string inverter, resulting in equipment damage.
4. When connecting the wiring of the external cable to the string inverter, the installation torque of the power cable must be ensured. Excessive torque may cause fatigue damage of the screw while too small torque may cause the contact resistance to become large, resulting in overheating.
5. The power cable terminals connected to the string inverter must comply with national standards. If the terminals are not in accordance with the standards, the power cable may be overheated. In severe cases, a fire may occur.
6. The installation site must meet the requirements of the operating environment. Please refer to [2.10 Environmental Requirements](#).

1.4 Operating



1. During the operation of the string inverter, it is necessary to ensure that the door panel of the string inverter is locked to prevent personal injury such as electric shock, and to prevent salt, moisture, dust or other conductive substances in the air from entering the string inverter.
2. When the string inverter is powered on, it is prohibited to touch the internal single boards, devices, cables and terminals of the string inverter and to plug and unplug the external terminals.

3. In case of any fault, abnormal smell or sound of the string inverter, please immediately switch off the DC Switch of the string inverter and the circuit breaker on the AC side of the inverter.



1. Power on the string inverter only after all installation work is completed and cables are not connected incorrectly.
2. It is prohibited to conduct any insulation resistance test or voltage withstand test on the string inverter. Wrong voltage withstand test will damage the string inverter.
3. When conducting insulation withstand voltage test on external equipment of the string inverter, the wiring between the string inverter and the external equipment must be disconnected.

1.5 Maintenance



1. Before maintenance work, you must first disconnect the AC output side circuit breaker, then disconnect the input switch DC Switch, and wait at least 5 minutes before operating the string inverter.
2. During the maintenance process, try to avoid irrelevant personnel from entering the maintenance site.
3. Please maintain the string inverter under the condition that you are familiar with and understand the contents of this manual, and have suitable tools and test equipment.
4. For personal safety, please wear insulating gloves and anti-smashing shoes.



The string inverter must be checked and maintained regularly. For details, refer to [5 Maintenance and Troubleshooting](#).

--End of the chapter--

2 Product Description

2.1 Product Introduction

The EVVO series string inverter is three-phase string-type grid-connected inverter independently developed by EVOLVE ENERGY GROUP Technology. Its main function is to convert the DC power generated by the PV string into AC power and feed it into the power grid.

- EVVO 60 has 12 input interfaces;

EVVO 60 is suitable for 400VAC low-voltage grid-connected scenarios, such as village-level photovoltaic power stations or industrial and commercial rooftop photovoltaic power stations below 400kW.

2.1.1 Schematic Diagram

PV strings are connected to the inverter through branches. There are MPPT circuits inside the inverter to track the MPPT of the strings, and then convert the DC power to three-phase AC power through the inverter circuit. The schematic diagram is shown below.

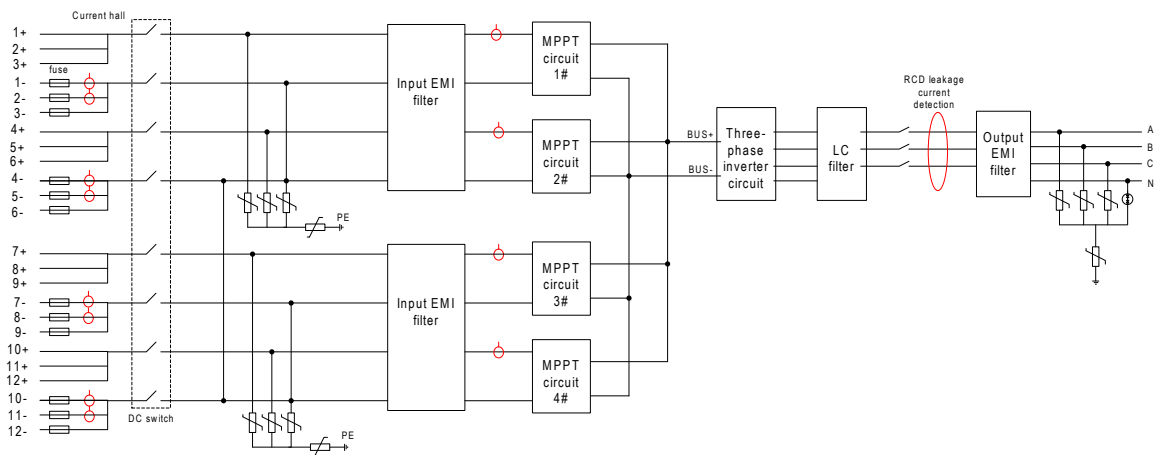

Figure 2-1 Schematic diagram of EVVO 60

2.1.2 Operating Mode

EVVO three-phase string inverter has three working modes: standby mode, running mode, and shutdown mode. The switching conditions of the three modes are shown as follows.

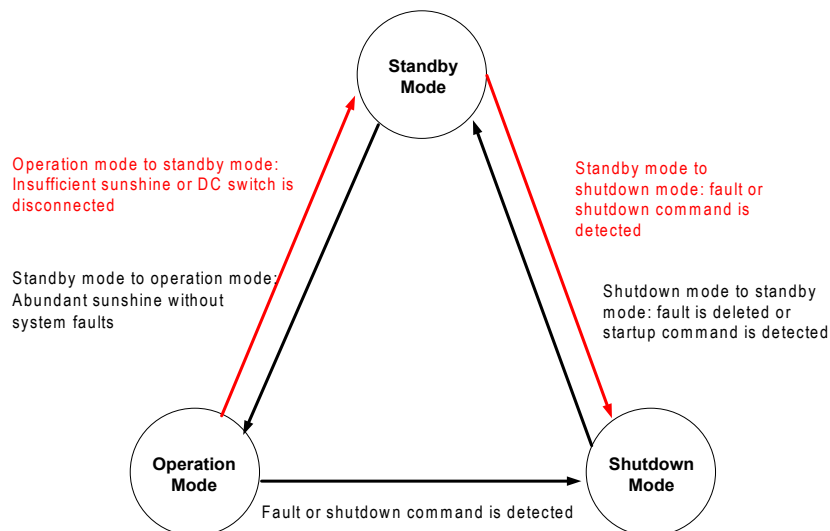

Figure 2-2 EVVO string inverter operating mode

Operating mode	Description
Standby	<p>1) Standby mode mainly means that the external environment does not meet the operating conditions of the inverter such as insufficient light and the disconnection of DC input switch. In this mode, the inverter continuously self-tests and enters the operating mode once the operating conditions are met.</p> <p>2) In the standby mode, if the inverter detects a shutdown command or finds a fault after the power-on test, it enters the shutdown mode.</p>
Running	<p>In the running mode, the inverter converts the DC power of the PV string into AC power and feeds it into the grid.</p> <p>The inverter performs MPPT operation to make the PV string output maximum power.</p> <p>If the inverter detects a fault or a shutdown command, it enters the shutdown mode.</p> <p>If it is detected that the input power of the PV string is lower than the grid-connected power generation condition, it enters the standby mode.</p>
Shutdown	<p>If the inverter detects a fault or a shutdown command during standby or operation, it switches to the shutdown mode.</p> <p>In the shutdown mode, if the inverter detects that the fault has been cleared or a power-on command, it enters the standby mode.</p>

2.2 System Configuration and Application

2.2.1 Application Description

Figure 2-5 shows the application of the string inverter, and Figure 2-6 shows the networking design scheme of the distributed PV power station.

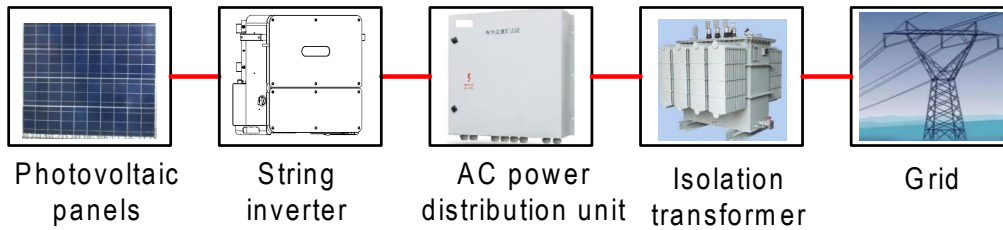

Figure 2-3 Application schematic diagram of string inverter

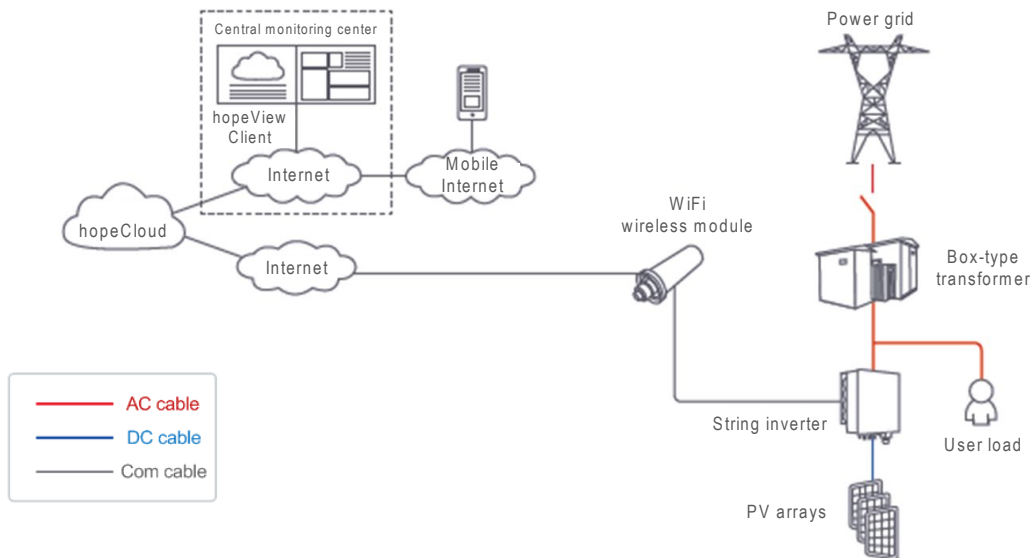

Figure 2-4 Networking scheme of distributed PV power station

2.2.2 Supported Grid Form

The power grid forms supported by EVVO 60 includes TN-S, TN-C, TN-C-S, TT, IT.

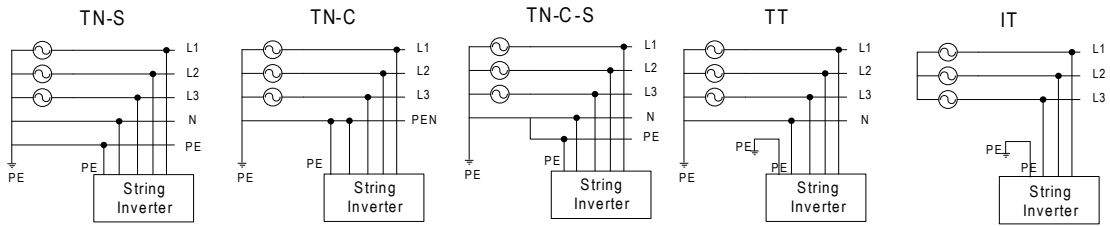

Figure 2-5 Schematic diagram of various power grid forms

2.3 Naming Rules

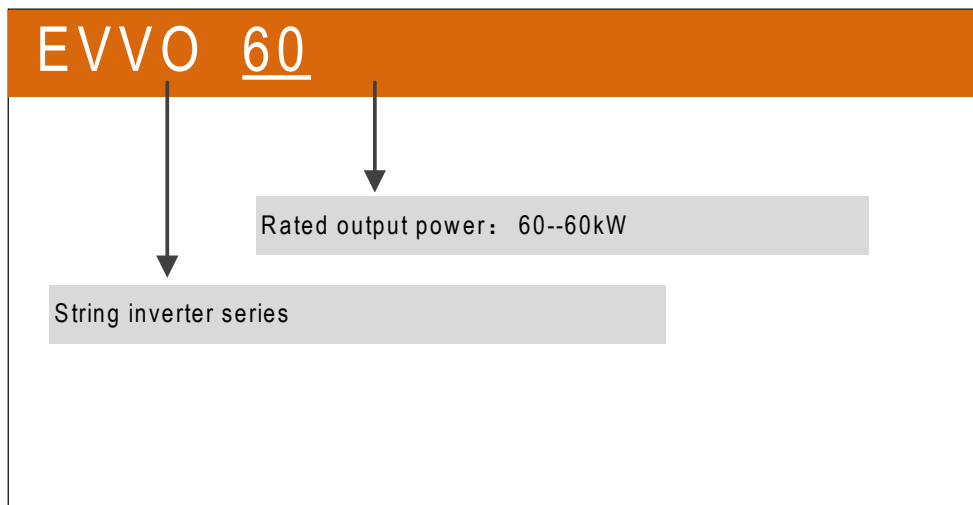



Figure 2-6 Naming rules

2.4 Nameplate Label

EVVO	
Product Name	PV Solar Grid Tie Inverter
Model	EVVO 60
Max. DC Input Power	90kW
Max. DC Input Voltage	1100Vdc
MPPT Voltage Range	200-1000Vdc
Max.DC Input Current	4x45Adc
Max. short circuit input current	4x60Adc
Rated AC Grid Voltage	3L/N/PE 400V
Rated AC Grid Frequen	50/60Hz
Rated AC Output Pow	60kW
Max. Active Power	66kW
Max. Apparent Output Pow	66kVA
Max. AC Output Current	95Aac
Power Factor	-0.8~+0.8
Operating Temperature Range	-40°C~+60°C
Ingress Protection	IP65
Protection Level	Class I
Serial Number	
Manufacturing Date	
	
Safety Warning	
	 The AC and DC circuits must be disconnected separately, 5min and the maintenance personnel must wait for 5 minutes before they are completely powered off before they can start working.
	It is strictly forbidden for users to open the casing. Professional maintenance is required for internal maintenance of the inverter.
	Surface high temperature, Please do not touch the inverter case.
	The DC input terminals of the inverter must not be grounded.
	Please read the instructions carefully before use.

 **Note: The data is for reference only. For more details, please refer to the physical object or technical agreement of the corresponding product.**

2.5 Inverter Configuration

This section describes the internal components, back components and bottom interfaces of the string inverter.

 **Note:** There are 12 groups of PV terminals at the bottom in EVVO 60.

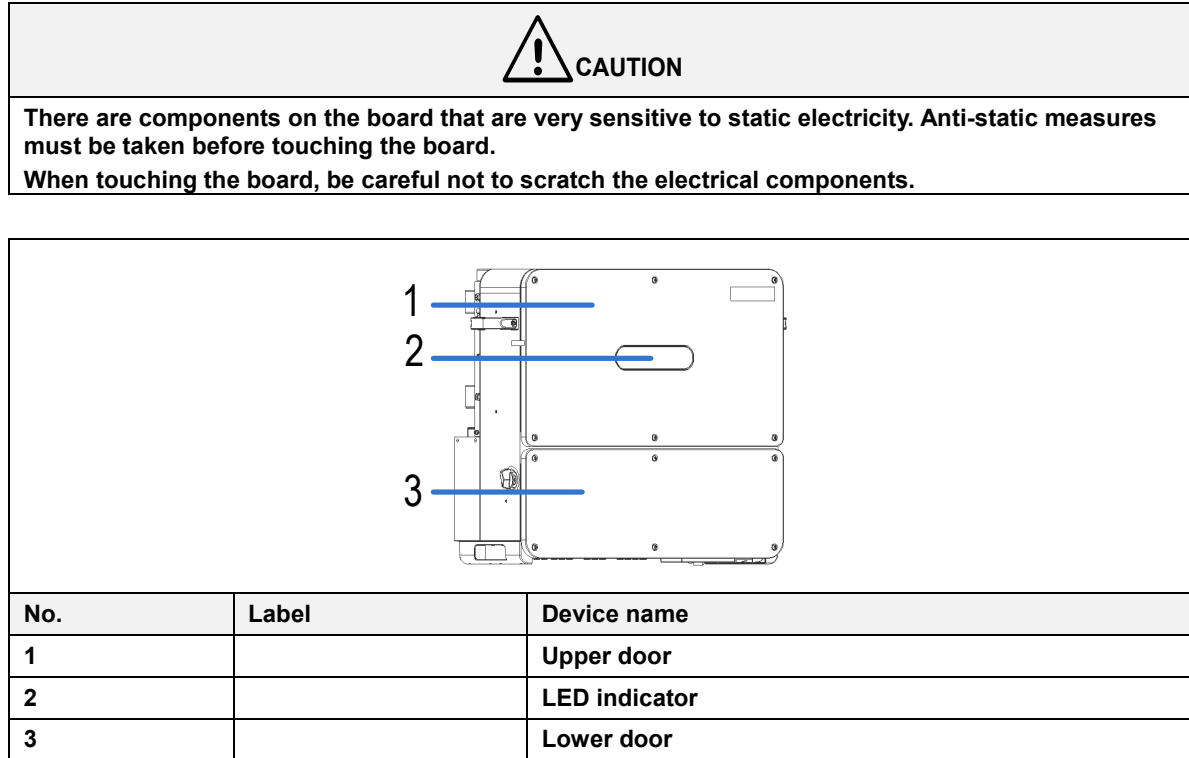
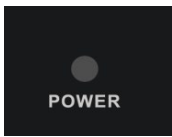
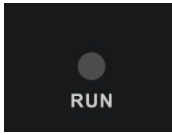
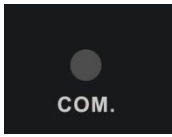
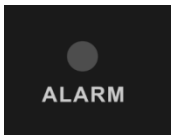

Figure 2-7 Front view of the inverter

The LED indicators from left to right are described as follows:

Table 2-1 LED Indicator Description

Indicator light	Meaning	Status	Description
	PV and grid connection	Blue light on	The PV side and the grid are connected normally
		Blue light fast blinking	The grid is connected normally but the PV side is connected abnormally
		Blue light slow blinking	The PV side is connected normally but the grid is not connected
		Blue light off	Both the PV side and the grid are not connected
	Grid-connected operation	Blue light on	The inverter is in grid-connected power-on state
		Blue light off	The inverter is neither grid-connected nor powered on
	Communication indication	Blue light quick blinking	Communication normal
		Blue light off	Communication abnormal
	Alarm indication	Red light slow blinking	Prompt alarm: PID power supply operation instruction
		Red light fast blinking	Abnormal alarm
		Red light solid on	Fault alarm

Remarks:
Slow blinking: 1 second on and 2 seconds off in cycles;
Fast blinking: 0.5 seconds on and 0.5 seconds off in cycles.

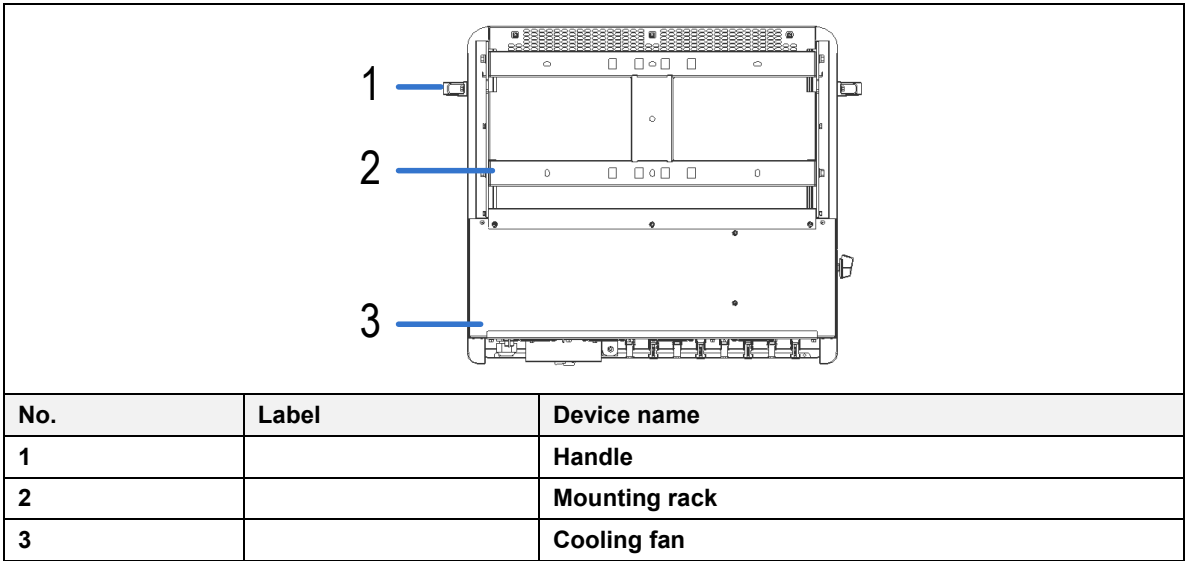

Figure 2-8 Back view of the inverter

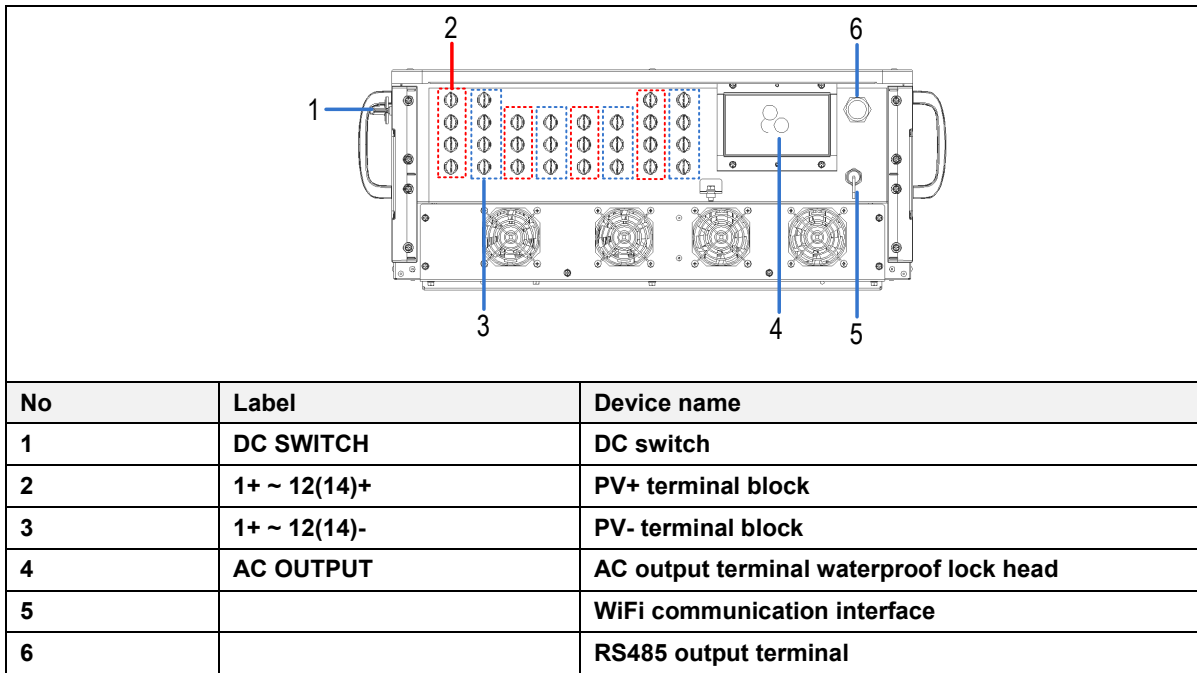
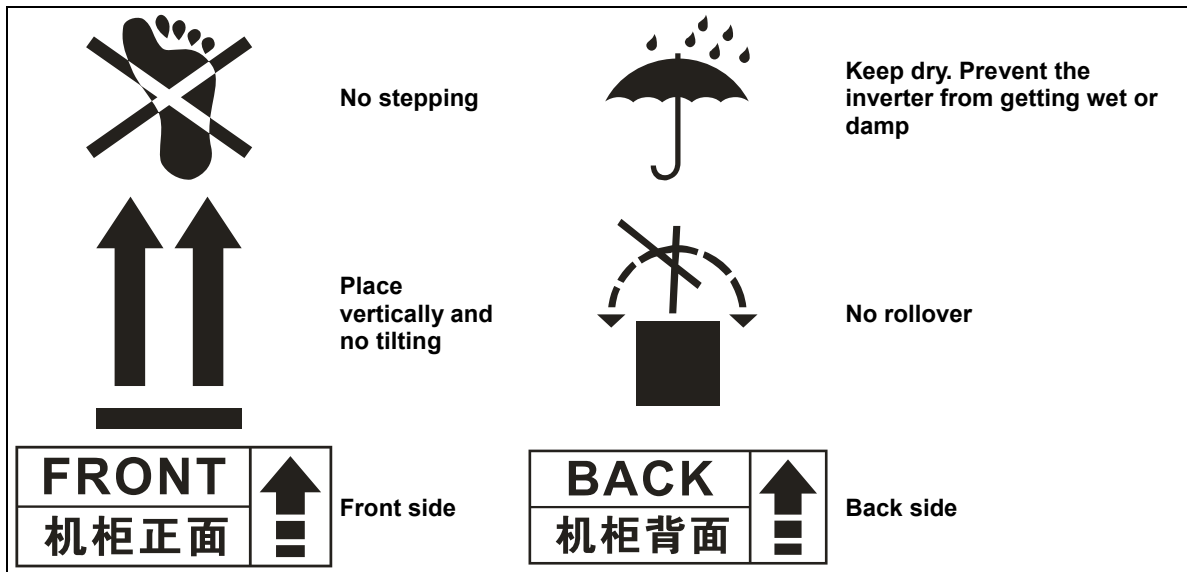

Figure 2-9 Bottom view of the inverter

2.6 Labels on the Package

On the outer packaging of the product, there are some labels to guide the user to transport and store the product. The meanings indicated by the logo are as follows:





2.7 Warning Signs on the Inverter

In order to ensure the personal and property safety of users when using this product and avoid accidents, the following warning labels may be placed inside and outside the string inverter to remind users of safety precautions during operation.

	Protective earthing: PE terminals need to be reliably grounded to ensure the safety of both operation personnel and equipment.
	General warning: This part may have other potential dangers except high voltage danger. Please watch out!
	High voltage danger: This part may have high voltage danger. Please watch out!
	Hot surface: Pay attention to the hot surface to prevent burns.
	Refer to the user manual: Please refer to the corresponding instructions in the user manual before operation.
	Discharge identification: This equipment has an energy storage device. Before maintenance, it is necessary to wait for the energy storage device to discharge to prevent electric shock. The waiting time is not less than the indicated discharge time.

2.8 Technical Data

	Model	EVVO 60
Input parameters	Maximum input voltage	1100V
	Minimum working voltage	180V
	Working voltage range	200V~1000V
	MPPT full load working voltage range	520V~850V
	Rated input voltage	650V
	Maximum input current per MPPT	45A
	Maximum short circuit current per MPPT	60A
	Maximum input ways	12
	Number of MPPT	4
Output parameters	Rated output power	60kW
	Maximum output apparent power	66kVA
	Maximum active power	66kW
	Rated output voltage	3*230/400V 3W+N+PE
	Output voltage range	300V~520V
	Rated output frequency	50Hz/60Hz
	Rated output current	86.6A
	Maximum output current	95A
	Power factor	-0.8~+0.8
	Maximum total harmonic distortion	<3%
Efficiency	Maximum efficiency	98.50%
	European efficiency	98.20%
Protection	Input DC switch	Supported
	DC polarity reverse protection	Supported
	DC surge protection	Class 2
	Insulation impedance test	Supported
	AC short circuit protection	Supported
	Output surge protection	Class 2
	String fault detection	Supported
	Protection against PID	Supported (night repair method)
RCD detection	Supported	
Display and communication	Display	LED; WLAN +APP
	RS485 communication	Supported
	Communication interface	WIFI/RS485
Conventional parameters	Dimensions (W * H * D)	705*650*297mm
	Weight	≤75kg
	Working temperature	-40°C~+60°C
	Maximum working altitude	4000m (> 3000m derating)
	Noise index	≤60dB
	Cooling mode	Smart air cooling
	Protection grade	IP65
	topological structure	Transformerless
	Input terminal	MC4 plugging terminal
Output terminal	Waterproof lock +OT/DT terminal	
Technical indicators	Standard of satisfaction	EN/IEC 62109-1, N/IEC 62109-2, NB/T 32004-2018

2.9 Mechanical Parameters

➤ Dimension and Weight

Model	Width * height * depth (mm)	Net weight (kg)
EVVO 60	705*650*297	≤75

📖 **Note:** Dimension of the inverter here does not contain hangers, handles, pads and other components. Dimensional error: + 10mm.

➤ Dimension of the Inverter and Mounting Rack

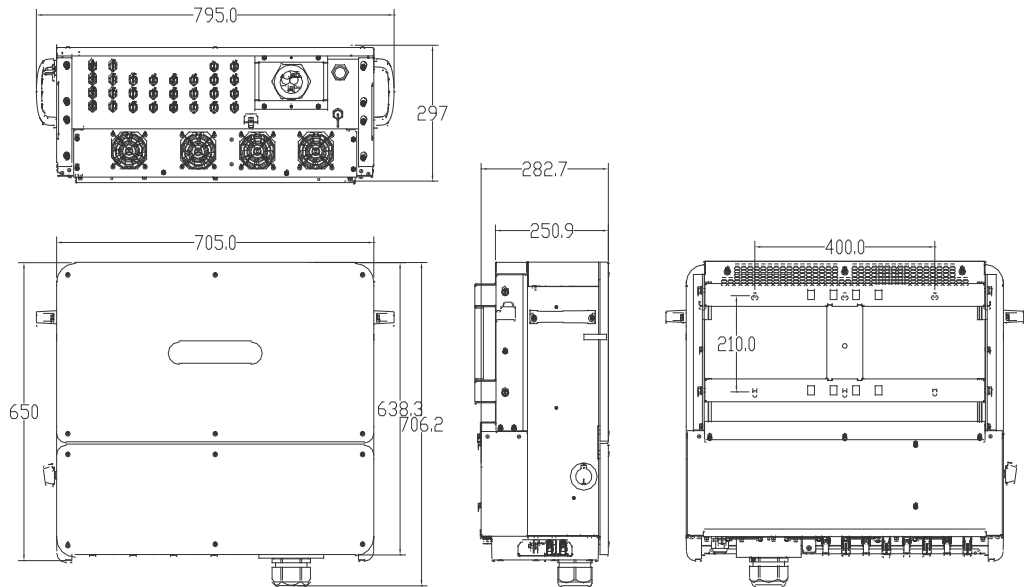

Figure 2-10 Dimensions of the inverter (unit: mm)

2.10 Ambient Requirements

Transportation environment	Requirements	
Type of shipping	Waterways, railways, highways, aviation, etc.	
Ambient temperature	-40°C ~ +70°C	
Relative humidity	≤95% when the temperature is +40°C	
Mechanical condition	The vibration should not exceed the following limits: 2Hz≤f<9Hz, displacement 7.5mm; 9Hz≤f<200Hz, acceleration 20m/s ² ; 200Hz≤f<500Hz, acceleration 40m/s ²	
Storage environment	Requirements	
Storage place	Store the product in a warehouse with air circulation, no harmful gases, no flammable or explosive materials, and no corrosive materials. Avoid strong mechanical vibrations and shocks and stay away from strong magnetic fields.	
Ambient temperature	-40°C ~ +70°C	
Relative humidity	≤95%	
Mechanical condition	The vibration should not exceed the following limits: 10Hz≤f<57Hz, displacement 0.075mm; 57Hz≤f<150Hz, acceleration 10m/s ² ;	
Working environment	Requirements	
	Normal operation state	Shutdown state
Installation place	Do not install the inverter in an area where flammable or explosive materials are stored. The installation site can be indoors or outdoors, preferably in a well ventilated environment. Avoid direct sunlight, rain and snow to extend the life of the inverter. It is recommended to install it in a sheltered location. If it is not possible, install an awning.	
Ambient temperature	-40 °C ~ +60 °C (Derating is required while the temperature is above 45 °C)	-40°C ~ +70°C
Relative humidity	Relative humidity: 0%~100%, internal condensation is not allowed.	
Altitude	≤4000m; derating is required when the altitude is above 3000m.	
Mechanical condition	The vibration should not exceed the following limits: 10Hz≤f<57Hz, displacement 0.075mm; 57Hz≤f<150Hz, acceleration 10m/s ² .	

--End of the chapter--

3 System Installation

3.1 Unpack and Inspect

After confirming that the outer packaging is intact, please carry out the unpacking inspection. Unpack the packaging box and check whether the appearance of the string inverter is in good condition. When opening the package, be careful to use the tool to avoid scratching the string inverter.

Although the inverter has been strictly tested and inspected before leaving factory, accidental damage might happen during transportation. Please inspect and check the product as soon as you receive it. If there is any damage or omission, please contact us and we will help you as soon as possible.

3.2 Installation Tool Preparation

Tool or device	Purpose	Remarks
4#Inner hexagon spanner	Disassemble and assemble of the lower door panel of the inverter	
Phillips screwdriver (PH2)	Fasten the grounding screws and pegboard screws	Bolt specifications: M6 and M8
Tube type crimping pliers	Crimp the communication cable terminals	
Socket wrench	Wire the output cable	Bolt specifications: M8
MC4 crimping pliers	Crimp the MC4 terminals	The input cable needs to be crimped into the MC4 terminal before it can be connected to the PV+/PV- terminal on the inverter
MC4 removal tool	Remove MC4 terminal	
Wire stripper	Strip wire	
Multimeter	Measure voltage to ensure wiring and installation safety	
Safety equipment	Necessary labor protection	Insulating shoes, gloves, etc.

3.3 Installation Environment Requirements

- The environmental requirements for the installation of string inverter are shown in "1 Safety Precautions".
- The installation mode and position must be suitable for the weight and dimension of the string inverter. See "2.9 Mechanical Parameters".
- The string inverter should be installed in a well ventilated environment to ensure good heat dissipation. Avoiding inverter direct sunlight, rain and snow can prolong the life of inverter. It is recommended to choose sheltered installation sites. If that cannot be satisfied, please set up a sun shading shelter.
- During the operation of the string inverter, the temperature of the chassis and the radiator will be relatively high. Do not install the inverter in the position which will be touched unintentionally.

3.4 Reserved Space Requirement

When installing the string inverter, the space around the string inverter must be reserved for heat dissipation and maintenance.

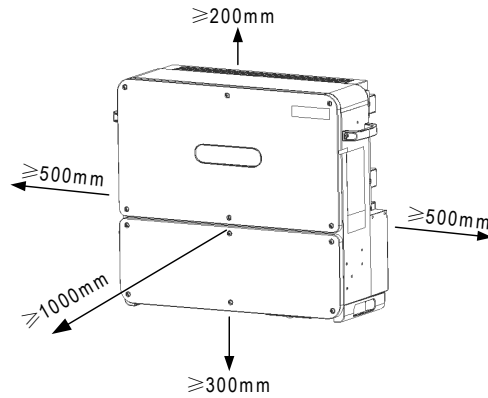

Figure 3-1 Reserved space requirements

When installing multiple string inverters in a same surface, the side by side installation is recommended.

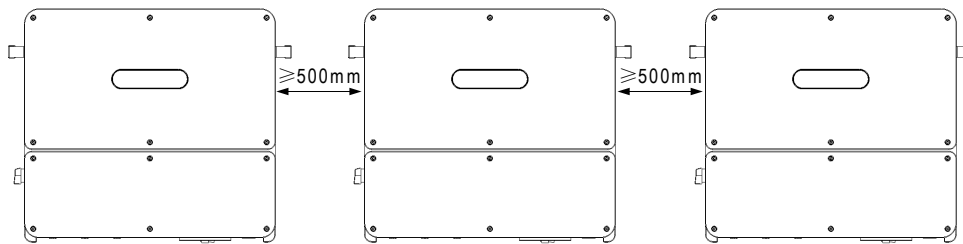

Figure 3-2 Side by side installation space

When installing multiple string inverters in two lines, the triangle installation is recommended.

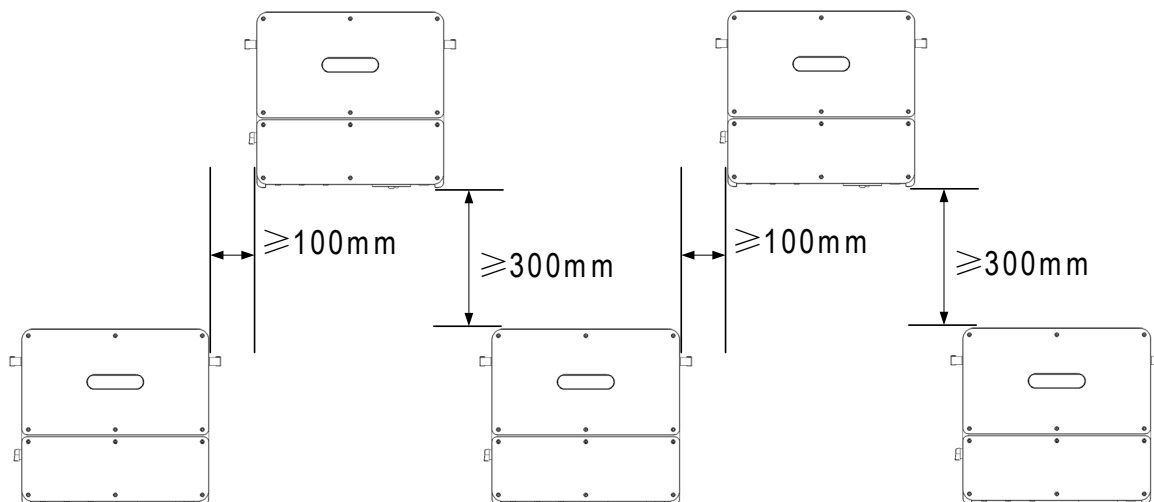

Figure 3-3 Triangle installation space

3.5 Installation Method

A hanging board is attached to the package of the string inverter. Fixed hanging board should be installed before the inverter is mounted and fastened on the hanging board. According to the actual installation environment, two installation modes can be selected, i.e. column-holding/rod-holding and wall-hanging.



1. Please refer to 1 Safety Precautions for precautions during inverter installation. For installation environment requirements, please refer to 3.3 Installation Environment Requirements.
2. During installation, it must be confirmed that the site installation position can bear the total weight of the inverter and accessories to avoid falling during installation or use.
3. It is recommended that two people work together to fix the inverter to avoid mechanical injury. During installation, safety measures shall be taken to prevent injuries.
4. Please install it vertically or tilt it back 15 ° at most to facilitate heat dissipation of the machine. Do not tilt the inverter (tilt forward, tilt back too much, roll), horizontally or upside down.
5. If it is impossible to avoid direct sunlight, please add a sunscreen.

3.5.1 Hoop Mounting

Installation steps

1. Take out the hanging plate in the package and confirm the front, back, and top of the hanging plate;
2. Use at least 2PCS hoops on the back side of the slats through the ferrule mounting holes (You need prepare the hoops by yourself);
3. Place the hanging plate in the installation position and fasten the band;
4. Before hanging the inverter, please confirm that the bearing range meets the requirements;
5. Hang the inverter on the hanging plate and fasten the connecting plate and inverter from both sides with 4PCS M8 screws (supplied accessories);
6. The installation process ends and the actual effect is as shown below:

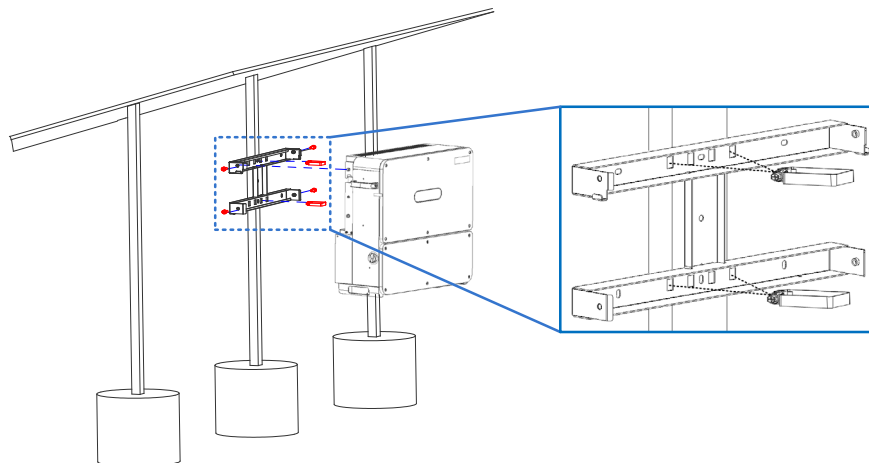

Figure 3-4 String inverter hoop mounting diagram

3.5.2 Screw Rod Mounting

Installation steps

1. Take out the hanging plate in the package and confirm the front, back, and top of the hanging plate;
2. Use the 3 PCS M8 screws (supplied accessories) to secure the hanging plate to the mounting position;

3. Before hanging the inverter, please confirm that the bearing range meets the requirements;
4. Hang the inverter on the hanging plate and fasten the plate and inverter from both sides with 4PCS M8 screws (supplied accessories);
5. The installation process ends and the actual effect is as shown below:

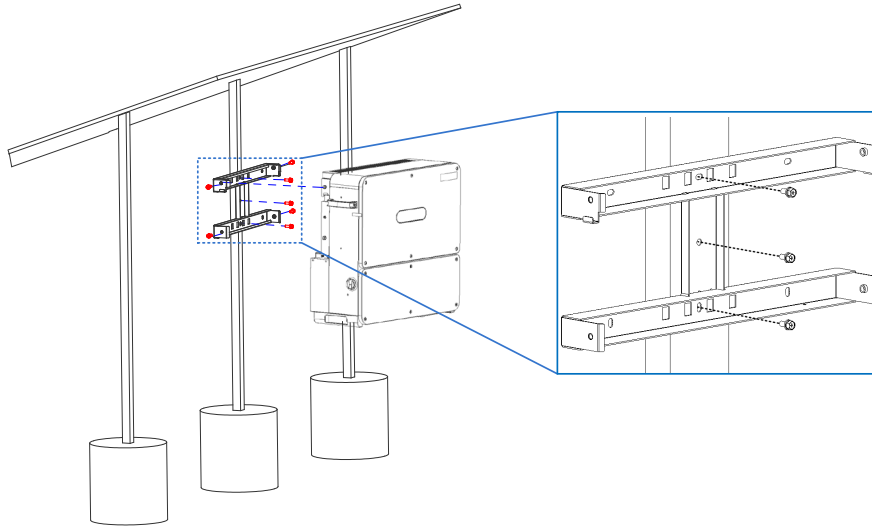



Figure 3-5 String inverter screw rod mounting diagram

3.5.3 Wall/Bracket Mounting

 This type of mounting allows the inverter to be mounted on a load-bearing wall or bracket. If you need to install the inverter on the wall, please purchase M8 expansion screws and punch holes on the wall for installation according to the site installation environment, wall bearing and other factors.

Installation steps

1. Take out the hanging plate in the package and confirm the front, back, and top of the hanging plate;
2. If necessary, punch holes in the wall or bracket according to the size of the mounting hole of the hanging plate;
3. Wall mounting: Fasten the mounting plate to the wall using 4PCS M8 expansion screws;
4. Bracket mounting: Fasten the mounting plate to the bracket using 4PCS M8 screws (supplied accessories);
5. Before mounting the inverter, please ensure that the installation surface is strong and meets the load-bearing requirements;
6. Hang the inverter on the hanging plate and fasten the connecting plate and inverter from both sides with M8 screws (supplied accessories);
7. The installation process ends and the actual effect is as shown below:

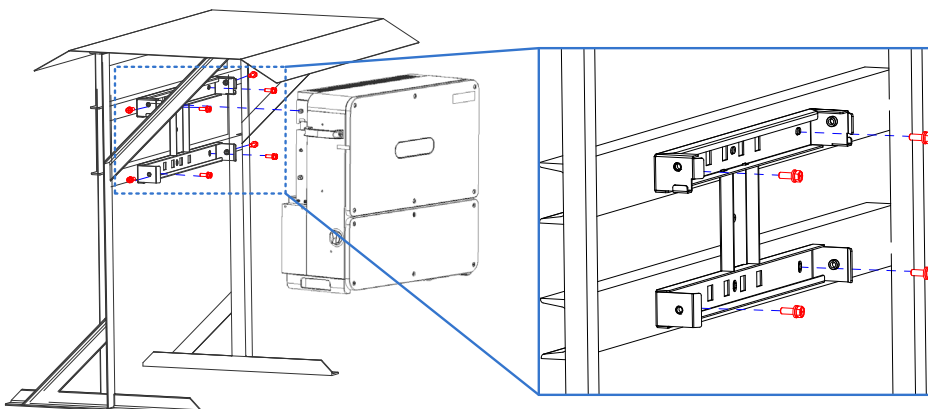

Figure 3-6 String inverter wall/bracket mounting diagram

3.6 Electrical Connections

3.6.1 Cable Requirements

The choice of cable should comply with relevant national standards and meet the load requirements.

Power cable requirements

Refer to the electrical data in the product data, and then consider the ambient temperature, current, margin and other factors to select the cable.

Communication cable requirements

Since weak communication signals are susceptible to external interference, the communication cable requires a shielded cable with the shield grounded as shown in the following figure. Also refer to the relevant document *GB 50217-2007 Cable Design Specification*.

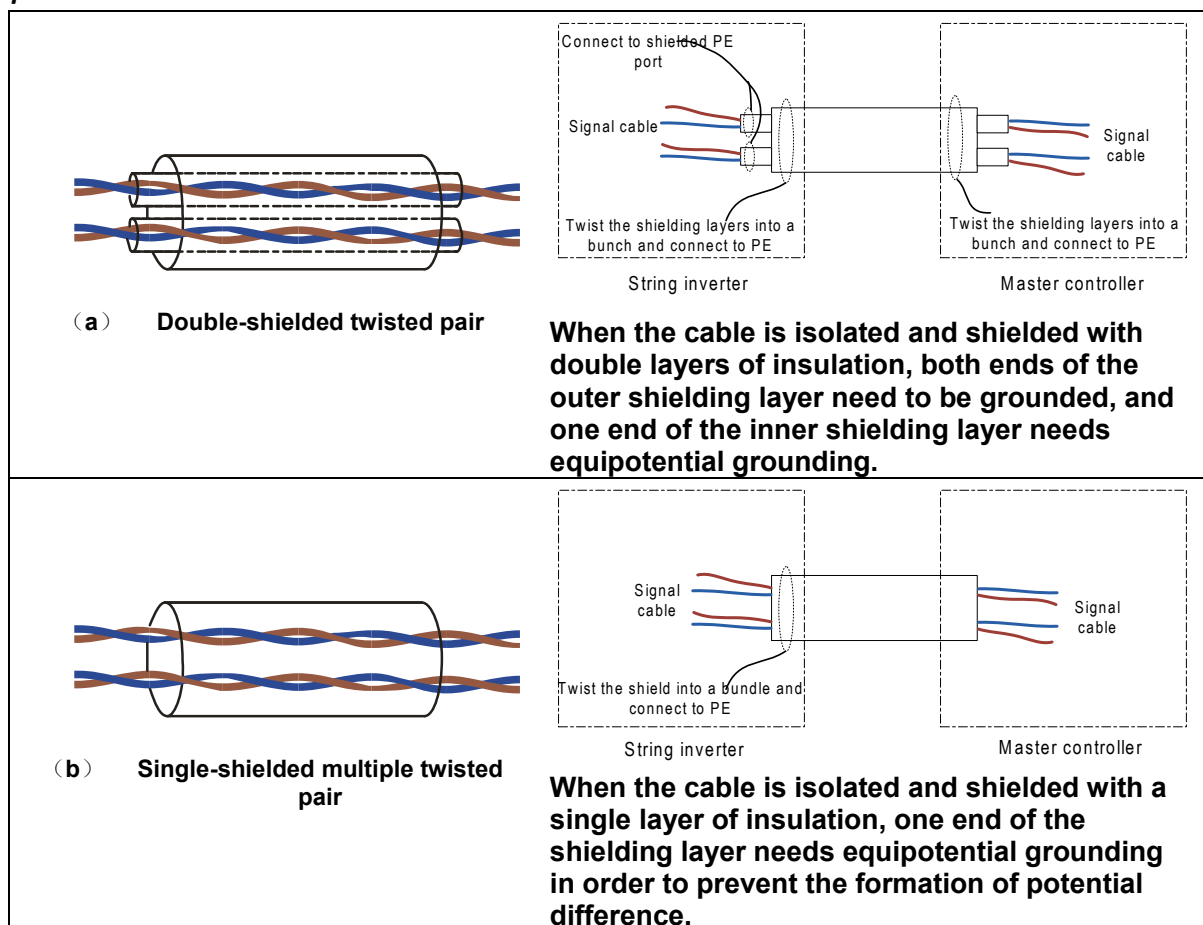

Figure 3-7 Twisted pair with shielding layer

The RS485 communication cable generally has four thin wires (blue, brown, gray, and black, respectively) and one shielded grounded copper wire. When wiring, cut off the gray line, use the blue line, brown line and black line, as shown below, and wrap the shield grounding copper wire on the black line (need to ensure that the copper wire is longer than the black line, To prevent the copper wire from being pulled off, connect the RS485 PE terminal).

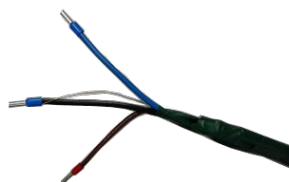

Figure 3-8 Schematic diagram of RS485 communication cable

3.6.2 Cable Selection

Name	Label	Recommended Cable Specifications	Note
PV branch input cable	1+ ~12(14)+ 1- ~12(14)-	Industry general photovoltaic cable, model: PV1-F. It is recommended to use 4.0mm ² -6.0mm ² copper cable for each PV + and PV branch.	--
AC output cable	A、B、C、N	4 core outdoor cable (A, B, C, N) or 3 core outdoor copper cable (A, B, C). Recommended cross sectional area of conductor: 35mm ² -70mm ² .	The AC output has only 1 waterproof locks with a specification of 42mm~50mm. The output is a Φ8 terminal. When the screw is locked, use the sleeve to correct the force.
RS485 communication cable	X3-P2 X3-P3	It is recommended to use a special communication cable or 4-core or 2-core shielded twisted pair cable with a cross-sectional area of not less than 0.75mm ² .	The RS485 communication cable has only one waterproof lock and the size is 13mm~18mm.
PE cable	PE	If the cross-sectional area S of the AC cable is greater than 35mm ² , the cross-sectional area of the ground wire is not less than S/2.	--

3.6.3 Torque Requirement

The torque of all the cable connecting screws should meet the requirements in the table below to ensure the reliability of cable connection.

Table 3-1 Torque requirements for cable connection

Thread specification	Performance level 4.8		Performance level 8.8		Unit
	General connection	High-tightness connection	General connection	High-tightness connection	
M3	6	8			kgf.cm
M4	12	14			kgf.cm
M5	25	30			kgf.cm
M6	50	60			kgf.cm
M8			110	150	kgf.cm
M10			300	390	kgf.cm
M12			550	650	kgf.cm
M16			1600	2000	kgf.cm

 Note: Inside the string inverter, the bolts with the nominal diameter of the external thread above 8mm are 8.8 Dacromet bolts.

3.6.4 Preparation before Operation

DANGER

1. When connecting cables, do not operate when the product is energized and please follow the relevant requirements in [1 Safety Precautions](#).
2. Before connecting the cables, please complete the following preparations to avoid personal injury.
 - 1) Before electrical connections, please make sure that the "DC SWITCH" of the inverter is in the "OFF" state, otherwise the high voltage of the inverter may cause a shock hazard.
 - 2) Determine the positive and negative poles of the input cable and mark them, and make sure that the input cable is disconnected from the PV string.
 - 3) Please confirm that the open circuit voltage of the PV string does not exceed the specified limit.
3. When connecting the input cable, please make sure that the positive and negative terminals of the input cable correspond to the positive and negative terminals of the PV inverter of the string inverter.

 **Note:** The following figures are using 9-input string inverter for example, which is similar with the structure of other models.

3.6.5 Connect the Ground Wire

Connect the inverter to the grounding bar through the protective earth wire to achieve the purpose of grounding protection. The PE mark is affixed to the PE terminal. Use a fixed connection and the cross-sectional area of the protective grounding conductor is not less than 16mm² (copper wire). The bolt size is M6.

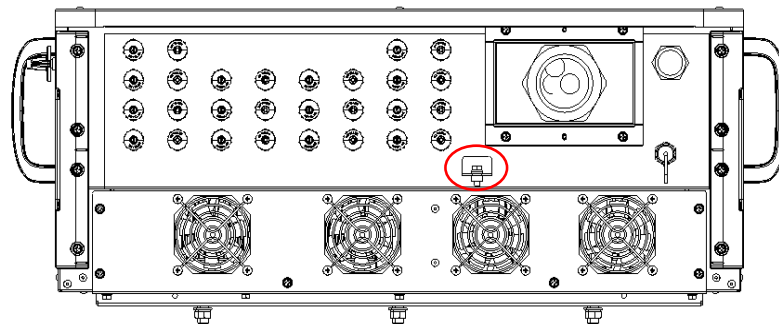

Figure 3-9 PE connection

For the grounding of multiple string inverters, use single-point grounding instead of winding the ground wire into a ring shape as shown below.

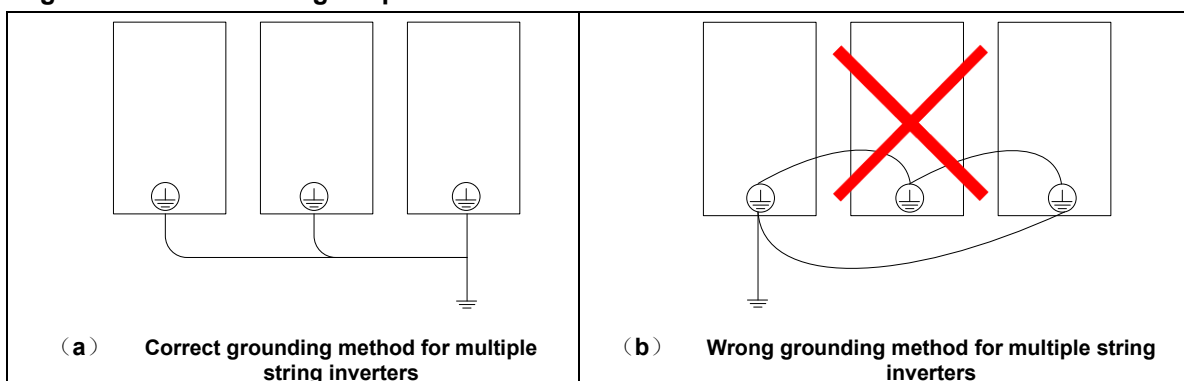

Figure 3-10 PE connection of multiple string inverters

3.6.6 Open the Lower Door Panel



CAUTION

- 1) Do not open the chassis door on the top of the inverter.
- 2) Before the inverter opens the door, it must be ensured that the AC and DC are powered off.
- 3) Please keep the 6 screws on the chassis door. Do not leave unused screws inside the chassis.

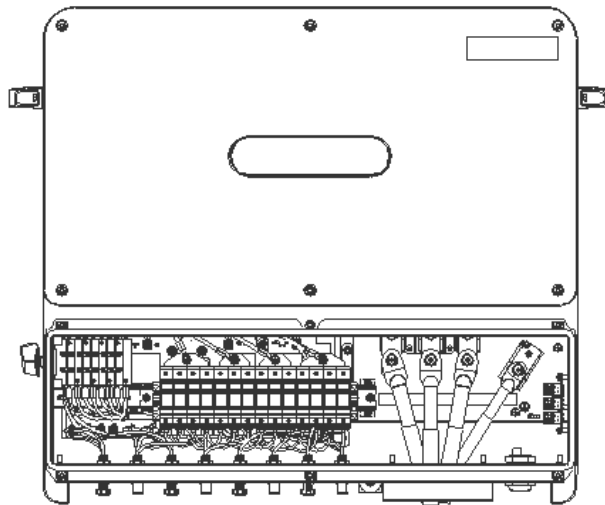

Figure 3-11 Disassemble the lower door panel

3.6.7 Connect the AC Output Cable

Precautions

- An independent three-phase circuit breaker is required outside the AC side of each inverter to ensure reliable disconnection between the inverter and the power grid. And the circuit breaker specifications meet the technical requirements.
- It is forbidden to share one circuit breaker for multiple inverters
- It is forbidden to connect the load between the inverter and the circuit breaker.
- The user must prepare the OT terminal (model: M8) by himself, and the maximum cable is 95mm².

Operations

- 1) Crimp the OT terminal and wrap the crimp with a heat shrink tubing or insulating tape.
- 2) Unscrew the locking cap on the “AC OUTPUT” waterproof lock on the bottom of the inverter.
- 3) Pass the completed AC cable into the lock cap and the “AC OUTPUT” waterproof lock on the bottom of the inverter.
- 4) Connect the AC cable to the tightening torque of 8N*m on A, B, C, and N of the AC terminal block.
- 5) Lock the locking cap. Check for gaps in the waterproof lock. If there is a gap in the waterproof lock, use a fireproof mud to block the gap.

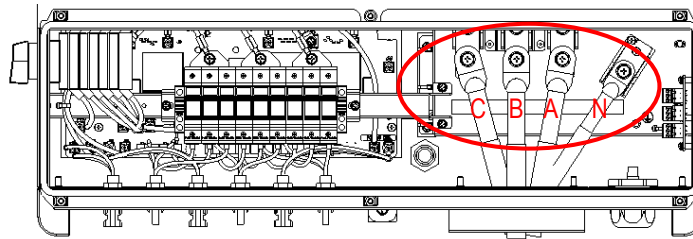

Figure 3-12 AC wiring terminals connection

3.6.8 Connect Communication Cable

Choice of communication method

The inverters support RS485 communication mode.

Cable connection instructions

The inverter is connected to a communication device (such as a data collection cabinet or a PC) via an RS485 communication line. On the RS485 adapter board X3, two RS485 interfaces (labeled P2, P3), as shown below.

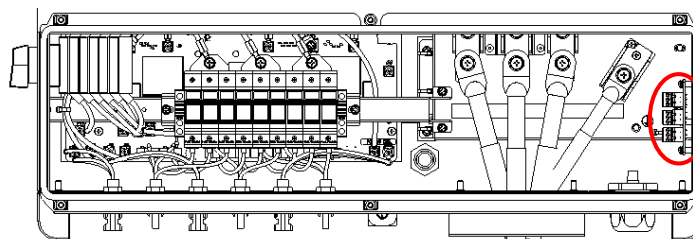

Figure 3-13 Position of X3 signal adapter board

Pass the RS485 cable through the RS485 waterproof lock on the bottom of the inverter (the operation steps are similar to the AC OUTPUT waterproof lock) and connect to the RS485 interface on the RS485 adapter board X3. The connection of multiple inverters is recommended to be connected in series as shown below.

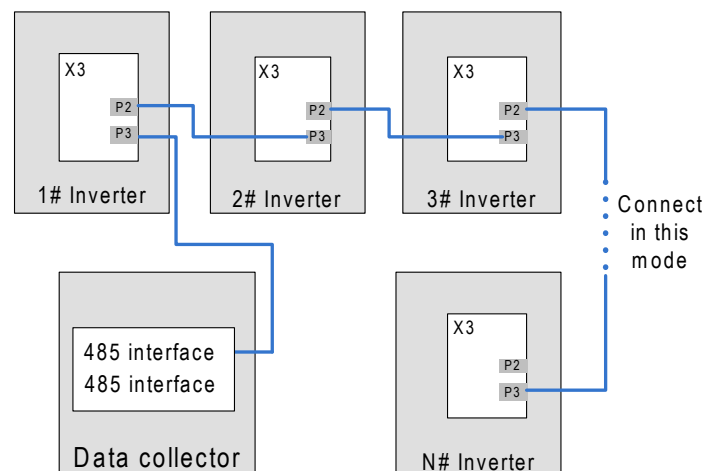



Figure 3-14 Schematic diagram of multiple inverter serial signal cable connections

 **Note:** When the communication distance exceeds 300m or the field communication quality is poor, the terminal matching resistors of the last inverter shall be short-circuited by pulling a jumper cap from the X3 board and short-circuiting the Pin1 and Pin2 of JP13 on the EVVOM5 board.

Lock the locking cap when the connection is complete. Check for gaps in the waterproof lock. If there is a gap in the waterproof lock, use a fireproof mud to block the gap.

3.6.9 Connect the DC Input Cable

 In order to make full use of the DC input power, the PV strings of the same input MPPT should be identical in structure, including the same model, the same number of panels, the same tilt angle, and the same azimuth.



1. When the sun shines on the battery panel, it will generate voltage which may cause life-threatening dangers. Therefore, if the DC input line is connected under light conditions, you need to ensure that the input line is not charged (you can cover the panel with an opaque cloth and then proceed operating).
2. Before connecting the input cable, make sure that the DC side voltage is within the safe voltage range which is within 60VDC, and the DC switch is in the “OFF” state, otherwise the high voltage generated may cause a shock hazard.
3. When the inverter is running in the grid, it is forbidden to perform maintenance operations on the DC input cable, otherwise it will cause electric shock hazard.
4. If you want to remove the positive and negative connectors, make sure that DC switch has been placed in the “OFF” state and there is no current output from the PV branch.



- Please ensure that the following conditions are met, otherwise it may cause a fire hazard.
- Each component of the string in series is of the same specification.
 - The maximum opening voltage of each PV string cannot be greater than 1100 VDC under what circumstances.
 - The maximum short-circuit current of each PV string shall not exceed 30A under any conditions.
 - Ensure that the polarity input on the DC input side is correct, that is, the positive pole of the PV module is connected to the positive pole of the DC input terminal of the inverter, and the negative pole is connected to the negative pole of the DC input terminal of the inverter.

Precautions for grounding the PV string

If the inverter is directly connected to the N-line of the power grid and connected to the PGND line (such as the low-voltage distribution network or the N-line and ground-connected power grid), the positive or negative pole of the PV string is prohibited from being grounded, otherwise the inverter will not be able to normal work.

DC input terminal selection

Number of input channels	DC input terminal
1	PV1
2	PV1、PV2
3	PV1、PV2、PV3
4	PV1 ~ PV3、PV4
5	PV1 ~ PV4、PV5
6	PV1 ~ PV5、PV6
7	PV1 ~ PV6、PV7
8	PV1 ~ PV7、PV8
9	PV1 ~ PV8、PV9
...	...
14	PV1 ~ PV13、PV14

Crimp MC4 terminal step

The input cable needs to be crimped into the MC4 terminal for connection to the string inverter PV+/PV- terminals. Before operation, ensure that “3.6.4 Preparation before Operation” has been completed.

1. The positive and negative poles of the input cable are determined and identified.

 **Note:** Please do not judge the positive and negative according to the cable color in this manual. Be sure to take the actual measurement as the standard.

2. Use a wire stripper to strip the wire.

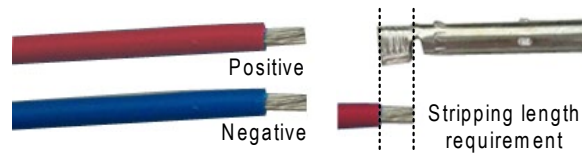

Figure 3-15 Strip wire

3. According to the correct polarity, crimp the cable to the corresponding core.

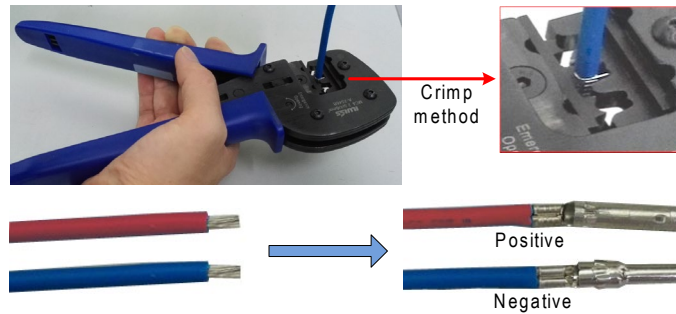

Figure 3-16 Crimp terminal

4. With the correct polarity, insert the core into the male and female ends of the MC4 connector and tighten the connector back cover.

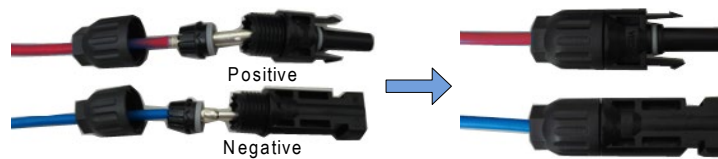

Figure 3-17 Assembly connector

Insert MC4 terminal

Insert the positive and negative connectors into the positive and negative terminals of the DC input terminal of the inverter until you hear a “click”, indicating that the terminal is stuck in place.



Please use the MC4 terminals configured in the delivery accessories. Device damage due to use of incompatible MC4 terminals is not covered by the warranty.

After the cable connection of the string inverter is completed, check if there is a gap at the waterproof lock. If there is a gap in the waterproof lock, use a fireproof mud to block the gap. If there are unconnected input terminals, seal the unconnected input terminals.

--End of the chapter--

4 Commissioning Guide

4.1 Check before Power On



- Before proceeding to the next step of power on, please read carefully this manual "1 Safety Precautions" and do a detailed check according to the table below.
- In order to avoid danger, the multimeter and other instruments must be used to detect the voltage of the metal parts inside the casing (protective ground) of the string inverter.

Once the string inverter is installed, the following items need to be checked carefully before power on.

Mechanical inspection

- Please read "1 Safety Precautions" carefully.
- Ensure that the environmental safety of the string inverter.
- Check if there are any foreign objects left inside and on the top of the string inverter cabinet.
- Ensure that the string inverter has enough space reserved around for maintenance and heat dissipation.
- The cables are marked clearly and correctly.
- Check if there any condensation inside the string inverter. If there is, remove it with heating tools.
- Ensure that all wiring screws are tightened according to torque requirements.
- Ensure RS485 wiring is correct and reliable.
- Make sure there is no gap between the input terminal and the waterproof lock.

Electrical inspection

- Ensure that the connection of the string inverter is reliable and the polarity is correct.
- The power cables and signal lines are all in conformity with the electrical safety regulations.
- Signal terminals and power lines are properly matched with terminals.
- The isolation area and warning signs have been set up around the string inverter to prevent others from misoperation or proximity.

4.2 System Power On

To ensure that the electrical connection is completed, the power on operation can be performed and the inverter will be turned on.

Step 1: Set the DC SWITCH of the inverter to the "ON" state.

Step 2: Close the AC circuit breaker between the inverter and the power grid.

If the system does not have any faults and all the startup requirements are met after all the above steps have been carried out, the inverter will start automatically.

4.3 System Power Off

Precautions

- After the inverter is powered off, there will be residual electricity and residual heat on the enclosure, which may cause electrical shock or burns. Therefore, please wait at least 5 minutes before you operate the inverter.

- **When powering off the system, please follow the sequence of operation instructions and safety regulations in this chapter.**

Step 1: Issue the shutdown command to the inverter through the data collector or near-end APP software.

Step 2: Disconnect the circuit breaker between the inverter and the power grid.

Step 3: Set the DC SWITCH of the inverter to the “OFF” state.

--End of the chapter--

5 Maintenance and Troubleshooting

5.1 Maintenance Items and Cycles

 DANGER	
<ol style="list-style-type: none"> 1. Please read 1 Safety Precautions carefully before maintenance, and use a multimeter and other relevant instruments to detect the voltage between the metal parts that need to be or maybe touched and the grounding copper bars so as to avoid electric shock. 2. During maintenance, please pay attention to the warning labels of the string inverter to avoid personal injury due to high voltage. 3. During maintenance, please make sure that the DC Switch is in off state, and the circuit breaker between the inverter and the grid is disconnected. 4. After the maintenance, close the DC input switch of the inverter and the circuit breaker between the inverter and the grid. 	

String inverters need to be regularly maintained. Common maintenance items and cycles are shown in the table below.

Table 5-1 Maintenance items and cycles of the string inverters

Parts	Item	Description	Solutions	Maintenance Cycle
Overall inspection	Appearance	Observe whether the inverter appearance is damaged or deformed.	Please replace it in time when it is serious.	Once every six months to one year
	System cleaning	Check if there are dusts and foreign matters on the surface of the inverter.	Clean up the foreign matters and dusts.	
		The heat sink is covered with dust and dirt.	Remove occlusion and clean dusts	
System running	Operating state	Check if there is any abnormal noise while the inverter is running.	If the problem is serious, please replace it in time.	Once every six months to one year
	Operating parameters	When the inverter is running, check whether the parameters are set correctly.	Troubleshoot abnormal settings	
Connection parts	Fall off or loose	Check if the cable connection is disconnected or loose.	Tighten connections as specified	Once every six months to one year
	Damage	Check if there is any damage on the cable. Especially check the surface of the cable that is in contact with the metal surface for traces.	If the problem is serious, please replace it in time.	
	Terminal	Check if the waterproof covers of the unused RS485, RJ45 or other terminals are locked tightly	Ensure that they are sealed well.	

 **Note:** Before wiping the heat sink, turn off the inverter normally, then disconnect the circuit breaker between the inverter and the grid, and then set the DC switch of the inverter into the OFF state. After powering off, wait at least 5 minutes before wiping the heat sink so as to avoid accidents.

5.2 Troubleshooting

Boost Side

Fault word	ID	Fault/alarm name	Fault/alarm reason	Troubleshooting
Fault word 1	0	Auxiliary power failure	$\pm 12V$ of the auxiliary power supply is too high or too low	<ol style="list-style-type: none"> 1. Check whether it can work normally after reset. 2. If it occurs frequently, please contact the EVOLVE ENERGY GROUP technician.
	2	Output hardware overvoltage	The output voltage exceeds the protection point set by the hardware.	<ol style="list-style-type: none"> 1. Check whether it can work normally after reset. 2. If it occurs frequently, please contact the EVOLVE ENERGY GROUP technician.
	3	Hardware overcurrent (secondary)	Unit inductor current is too large	<ol style="list-style-type: none"> 1. Check whether it can work normally after reset. 2. If it occurs frequently, please contact the EVOLVE ENERGY GROUP technician.
	4	Unit 1 hardware overcurrent	Unit 1 current overcurrent and reaches the hardware wave-by-wave current limit time	<ol style="list-style-type: none"> 1. Check whether it can work normally after reset. 2. If it occurs frequently, please contact the EVOLVE ENERGY GROUP technician.
	5	Unit 2 hardware overcurrent	Unit 2 current overcurrent and reaches the hardware wave-by-wave current limit time	<ol style="list-style-type: none"> 1. Check whether it can work normally after reset. 2. If it occurs frequently, please contact the EVOLVE ENERGY GROUP technician.
Fault word 2	2	EEPROM parameters back to default values	EEPROM read and write error	Fault reset or power off
	3	Historical fault storage failed	Historical fault storage failed	Fault reset or power off
	12	Input polarity reverse	Input polarity reverse	Check whether the polarity of the connection is reversed
	13	Insulation fault of the positive bus to the ground	Abnormal insulation impedance of the positive bus to the ground	Check whether the positive bus has grounding fault
	14	Insulation fault of the negative bus to the ground	Abnormal insulation resistance of the negative bus to the ground	Check whether the negative bus has grounding fault
Alarm word 1	6	Boost side alarm	Boost unit open circuit	Please contact the EVOLVE ENERGY GROUP technician.
	7	Boost side short circuit alarm	Boost unit short circuit	Please contact the EVOLVE ENERGY GROUP technician.
	8	Abnormal alarm of battery string	Abnormal battery string	<ol style="list-style-type: none"> 1. Check whether the battery string configuration is abnormal 2. Check whether the access of the battery board is abnormal 3. Check whether the current sampling of the battery string is abnormal
	9	Insulation alarm of the positive bus to the ground	Abnormal insulation impedance of the positive bus to the ground	Find out the cause of abnormal impedance

Fault word	ID	Fault/alarm name	Fault/alarm reason	Troubleshooting
	10	Insulation alarm of the negative bus to the ground	Abnormal insulation impedance of the positive bus to the ground	Find out the cause of abnormal impedance

Inverter Side

Fault word	ID	Fault/alarm name	Fault/alarm reason	Troubleshooting
System fault status word	0	RAM self test failed	Check RAM chip read and write error	1. Check whether it can work normally after reset 2. If it occurs frequently, please contact the EVOLVE ENERGY GROUP technician
	1	EEPROM parameters back to default values	Add EEPROM parameter list and upgrade the code again. After initialization, the default value is different from that in EEPROM	1. Check whether it can work normally after reset 2. If it occurs frequently, please contact the EVOLVE ENERGY GROUP technician
	2	EEPROM read and write failed		1. Check whether it can work normally after reset 2. If it occurs frequently, please contact the EVOLVE ENERGY GROUP technician
	3	FPGA version does not match	FPGA version does not match with that of DSP	1. Check whether it can work normally after reset 2. If it occurs frequently, please contact the EVOLVE ENERGY GROUP technician
	5	Internal communication failure	Internal communication failure	1. Check whether it can work normally after reset 2. If it occurs frequently, please contact the EVOLVE ENERGY GROUP technician
Hardware fault status word	0	Hardware overcurrent (secondary)	Inductor current peak exceeds hardware protection threshold	1. Check whether it can work normally after reset 2. If it occurs frequently, please contact the EVOLVE ENERGY GROUP technician
	3	Grid side hardware overcurrent	Phase A inductor current triggers wave-by-wave current limit protection	1. Check whether it can work normally after reset 2. If it occurs frequently, please contact the EVOLVE ENERGY GROUP technician
	6	Busbar hardware overvoltage	Bus voltage exceeds hardware overvoltage threshold	1. Check whether it can work normally after reset 2. If it occurs frequently, please contact the EVOLVE ENERGY GROUP technician
	7	Busbar midpoint overvoltage	Bus midpoint voltage exceeds hardware overvoltage threshold	1. Check whether it can work normally after reset 2. If it occurs frequently, please contact the EVOLVE ENERGY GROUP technician
Grid fault status word	0	Grid overvoltage	The grid voltage exceeds the overvoltage point set by the system	Confirm whether faults such as box transformer tripping occur at the AC side at the time of fault
	3	Grid undervoltage	The grid voltage is lower than the undervoltage point set by the system	Check whether the inverter has a phase loss or whether the box change contacts are suitable.
	6	Grid abnormality	Grid frequency and voltage exceed system setting range	1. Confirm whether the access to the grid is the nominal grid of the inverter; 2. Confirm whether the grid is connected

Fault word	ID	Fault/alarm name	Fault/alarm reason	Troubleshooting
	7	Grid voltage imbalance exceeds limit	Grid voltage imbalance exceeds system threshold	Check whether the grid is abnormal
	8	Grid overfrequency	The grid frequency exceeds the overfrequency point set by the system	1. Confirm whether the box transformer tripping and other faults occur on the AC side of the inverter through fault recording and event recording 2. Confirm whether the frequency range and the time setting is reasonable
	9	Grid underfrequency	The grid frequency is lower than the underfrequency point set by the system	1. Confirm whether the box transformer tripping and other faults occur on the AC side of the inverter through fault recording and event recording 2. Confirm whether the frequency range and the time setting is reasonable
	11	Island effect protection	Grid voltage loss	Detect the causes of grid voltage loss, such as box transformer tripping, etc.
	13	Grid voltage anomaly	Sudden change of grid voltage	Check if the grid is normal
	14	Low voltage ride through protection	Grid voltage exceeds LVRT protection threshold	Check if the grid is normal
	15	High voltage ride through protection	Grid voltage exceeds HVRT protection threshold	Check if the grid is normal
Inverter fault status word	0	Grid side software overcurrent	Inductor current effect value exceeds protection threshold	Reset the fault
	3	Module current imbalance	Three-phase current imbalance exceeds the threshold	Reset the fault
	5	Module temperature is too high	The radiator temperature is higher than the protection threshold.	Check whether the spoiler fan is normal
	6	High temperature inside the machine	Ambient temperature is higher than protection temperature.	Check whether the spoiler fan is normal
	9	Residual current abnormal	Residual current exceeds the limit	1. If it happens accidentally, it may be caused by the accidental abnormality of the external line. After the fault is cleared, it will resume work without manual intervention. 2. If it occurs frequently or cannot be recovered for a long time, please check whether the ground impedance of the PV string is too low.
Bus fault status word	1	Bus operation short circuit	Bus voltage sag exceeds limit	1. Check whether it can work normally after reset 2. If it occurs frequently, please contact the EVOLVE ENERGY GROUP technician

Fault word	ID	Fault/alarm name	Fault/alarm reason	Troubleshooting
	5	Bus operation over voltage	The bus voltage exceeds the set threshold	1. Check whether it can work normally after reset 2. If it occurs frequently, please contact the EVOLVE ENERGY GROUP technician
	6	Bus operation under voltage	The bus voltage is below the set threshold	1. Check whether it can work normally after reset 2. If it occurs frequently, please contact the EVOLVE ENERGY GROUP technician
	7	The bus voltage is unbalanced.	Positive and negative bus voltage imbalance exceeds the setting threshold.	1. Check whether it can work normally after reset 2. If it occurs frequently, please contact the EVOLVE ENERGY GROUP technician
	8	DC high input voltage	DC input voltage exceeds the setting threshold.	1. Check whether the components are over matched 2. Check whether the input voltage detection circuit is normal
	9	DC low input voltage	DC input voltage is below the setting threshold.	Check whether the switch is disconnected
Other	0	Grid-connected relay failure	Relay status error	1. Check whether it can work normally after reset 2. If it occurs frequently, please contact the EVOLVE ENERGY GROUP technician
	4	Internal fan fault	Fan failure or abnormal feedback signal	1. Check whether it can work normally after reset 2. If it occurs frequently, please contact the EVOLVE ENERGY GROUP technician.

--End of the chapter--

6 Inverter Handling Guide

6.1 Disassemble the Inverter

Before operating, make sure that the circuit breaker between the inverter and the grid is disconnected, and the DC switch is placed in the OFF state.

- 1) Disconnect all electrical connections to the inverter, including the AC output line, RS485 communication line, DC input line and protective grounding.
- 2) Remove the inverter from the hanging plate.

6.2 Replace the Inverter

After disassembling the old inverter, if it is necessary to replace it with a new inverter, follow the operation sequence in Chapter 3 and 4.

6.3 Package the Inverter

- If you still keep the original package of the inverter, please put it into the original package and firmly seal the package with tape.
- If you can't find the original package, please use a hard carton suitable for the weight and dimension of the inverter to firmly package it.

6.4 Scrap the Inverter

When the service life of the inverter expires or the inverter is replaced due to failure, it can be disposed according to the applicable electrical waste disposal laws of the place where the inverter is installed, or it can be handed over to EVOLVE ENERGY GROUP customer service personnel.

--End of the chapter--

Appendix

Warranty:

If the product has any fault in the warranty period, we will provide cost-free repair or replacement service.

Any faults arising from the following conditions shall be out of the warranty:

- Dismantle the product without our permission or maintain in wrong way;
- Out of the warranty period;
- Use the product out of the application scope stipulated in related international standard;
- Fail to install and operate the product according to the user manual;
- Use the product in improper environment;
- Use non-standard or those components/software not provided by our company;
- Damaged due to the failure of external devices;
- Any accidental damage arising from personal dismantlement or maintenance by yourself.

When the client requires repair service for above mentioned faults, we will offer paid repair service after it's determined by our service department. Please contact us in advance if you want repair or alteration service.

Contact US

EVOLVE ENERGY GROUP CO., LIMITED
Address: RM 702, 7/F FU FAI COMM CTR 27 HILLIER
ST SHEUNG WAN, HK
Global Head Quarters 371 Sidco Industrial Estate
Chennai 600098 India