

# EVVO

## String Inverter

(15K,20K,25K,30K)

# User Manual

Version: V1.2

---

Thank you for purchasing products developed and manufactured by EVOLVE ENERGY GROUP Co., Ltd. (hereinafter referred to as "EVOLVE ENERGY GROUP"). We hope our products and this manual can meet your demands. Any suggestion for improvement shall be highly appreciated.

EVOLVE ENERGY GROUP Co., Ltd. reserves the copyright of this manual, and it shall be subject to change without any further notice.



# About this manual



## For Readers

This manual is helpful for technicians who need to install, debug, operate and maintain the string inverter of EVOLVE ENERGY GROUP. Please read this manual carefully before operating the product. Readers are required to know some basic knowledge about electrical components, wiring, electrical symbols and mechanical drawings.

## Outlines

Chapter	Contents
1 Safety Precautions	This chapter describes the safety precautions when transporting, storing, installing, operating and maintaining the inverter.
2 Product Description	This chapter describes the basic principles, naming rules, machine configuration and product data.
3 System Installation	This chapter describes the unpacking inspection, installation tools, installation environment, reserved space, fixing method and cable connection.
4 Commissioning Guide	This chapter describes the inspection requirements before power on and how to debug and start up the inverter.
5 Maintenance and Troubleshooting	This chapter describes the daily maintenance methods, maintenance intervals and troubleshooting of the inverter.
6 Inverter Handling Guide	This chapter describes the basic requirements and precautions when disassembling, replacing, and scrapping the inverter.

## Warning Signs in This Manual

 <b>DANGER</b>	Major potential danger (especially refer to high voltage danger). Failure to observe the rules might cause severe personal injury or property loss.
 <b>WARNING</b>	Ordinary potential danger. Failure to observe the rules might cause personal injury or property loss.
 <b>CAUTION</b>	Ordinary potential danger. Failure to observe the rules might cause malfunction of the equipment or property loss.

## Glossaries and Abbreviations

Glossaries/Abbreviations	Description
MPPT	Maximum power point tracking
Photovoltaic string	Multiple solar cell arrays in parallel or series
EEPROM	Electrically erasable programmable read-only memory



# Content

<b>1 Safety Precautions</b>	<b>1</b>
1.1 Transport	1
1.2 Storage	1
1.3 Installation	2
1.4 Operating	2
1.5 Maintenance	3
<b>2 Product Description</b>	<b>5</b>
2.1 Product Introduction	5
2.1.1 Schematic Diagram	5
2.1.2 Operation Mode	5
2.2 System Configuration and Application	6
2.2.1 Application Description	6
2.2.2 Supported Grid Form	7
2.3 Naming Rules	7
2.4 Nameplate Label	8
2.5 Inverter Configuration	9
2.6 Labels on the Package	12
2.7 Warning Signs on the Inverter	12
2.8 Technical Data	13
2.9 Mechanical Parameters	15
2.10 Ambient Requirements	16
<b>3 System Installation</b>	<b>17</b>
3.1 Unpack and Inspect	17
3.2 Installation Tool Preparation	17
3.3 Installation Environment Requirements	17
3.4 Reserved Space Requirement	18
3.5 Installation Method	19
3.6 Electrical Connections	20
3.6.1 Cable Requirements	20
3.6.2 Cable Selection	20
3.6.3 Torque Requirement	21
3.6.4 Preparation before Operation	21
3.6.5 Connect the PE Cable	22
3.6.6 Connect the AC Output Cable	22
3.6.7 Connect the Communication Cable	23
3.6.8 Connect the DC Input Cable	24
<b>4 Commissioning Guide</b>	<b>27</b>
4.1 Check before Power On	27
4.2 System Power On	27
4.3 System Power Off	27
<b>5 Maintenance and Troubleshooting</b>	<b>29</b>
5.1 Maintenance Items and Cycles	29
5.2 Troubleshooting	30

<b>6 Inverter Handling Guide .....</b>	<b>35</b>
6.1 Disassemble the Inverter.....	35
6.2 Replace the Inverter.....	35
6.3 Package the Inverter .....	35
6.4 Scrap the Inverter .....	35

# 1 Safety Precautions

This chapter describes the safety precautions that must be observed when installing, operating and maintaining the inverter. Please read them carefully before operation and follow them in operation process; otherwise it might cause damage to the inverter, the generator and related equipment or cause serious injury or loss of life.

When you use and operate the inverter, please take special attention to:



1. Only the qualified personnel are allowed to install, operate and maintain the inverters.
2. Do not incline or collide the product in transportation.
3. Do not make any liquid, sundries or rubbishes enter inside as they might cause short circuit inside the inverter.
4. Inverter must be disconnected with AC grid before completion of installation and maintenance.
5. Related protective measures are required to avoid electric shock or fire accident.



Please do not place inflammables and explosives around the inverter to ensure environmental safety.

## 1.1 Transport



1. When transporting, it is necessary to ensure that the inverter is packaged properly and the cabinet is fixed upwards to avoid strong vibration and collision.
2. In order to keep the inverter in good condition during transportation, it must be transported with packaging and operated according to the labels on the package. For the meaning of the labels, please refer to **2.6 Labels on the Package**.
3. The transportation environment must meet the requirements. Please refer to **2.10 Ambient Requirements**.

## 1.2 Storage



The storage environment of the string inverter must meet the corresponding requirements. Please refer to **2.10 Ambient Requirements**.

### About long-term storage:

Before or after the installation and commissioning, if the string inverter is in the no-power supply state for more than three weeks, it is regarded as long-term storage. Long-term storage of string inverters requires attention to the following issues:

- Put the desiccant into the cabinet and package the whole machine with packaging materials.

- When storing equipment, pay attention to ventilation and moisture. Stagnant water is strictly forbidden in the storage environment.
- Pay attention to the harsh environment, such as quenching, sudden heat, collision, dust, etc., to avoid damage to the string inverter.
- Regular inspections are required, usually not less than once a week. Check whether the packaging is intact to avoid pest bites. If it is damaged, it needs to be replaced immediately.
- If the storage time exceeds half a year, the package should be opened for inspection, repackaged, and desiccant replaced.
- It is strictly forbidden to store the device without packaging.

### 1.3 Installation



1. Before operating the internals of the string inverter, it must be confirmed that the DC Switch of the string inverter and the circuit breaker corresponding to the AC side of the inverter are in the off state, and the housing of the inverter is reliably grounded.
2. The string inverter must be grounded according to the specifications. The size of the grounding conductor must meet the requirements of safety regulations to ensure the safety of personnel.



1. During installation, it is necessary to ensure that the string inverter's installation environment is well ventilated and heat-dissipating, and the device should not be directly exposed to sunlight.
2. The fixing of the string inverter is recommended by two people working together to avoid mechanical damage. During the installation process, safety measures should be taken to prevent bruises.
3. During installation and maintenance, it is necessary to prevent liquid, dust or debris from entering the inside of the string inverter. Conductive liquids and debris may cause internal short circuit of the string inverter, resulting in equipment damage.
4. When connecting the wiring of the external cable to the string inverter, the installation torque of the power cable must be ensured. Excessive torque may cause fatigue damage of the screw while too small torque may cause the contact resistance to become large, resulting in overheating.
5. The power cable terminals connected to the string inverter must comply with national standards. If the terminals are not in accordance with the standards, the power cable may be overheated. In severe cases, a fire may occur.
6. The installation site must meet the requirements of the operating environment. Please refer to **2.10 Ambient Requirements**.

### 1.4 Operating



1. During the operation of the string inverter, it is necessary to ensure that the door panel of the string inverter is locked to prevent personal injury such as electric shock, and to prevent salt, moisture, dust or other conductive substances in the air from entering the string inverter.
2. When the string inverter is powered on, it is prohibited to touch the internal single boards, devices, cables and terminals of the string inverter and to plug and unplug the external terminals.
3. In case of any fault, abnormal smell or sound of the string inverter, please immediately switch off the DC Switch of the string inverter and the circuit breaker on the AC side of the inverter.





1. Power on the string inverter only after all installation work is completed and cables are connected correctly.
2. It is prohibited to conduct any insulation resistance test or voltage withstand test on the string inverter. Wrong voltage withstand test will damage the string inverter.
3. When conducting insulation withstand voltage test on external equipment of the string inverter, the wiring between the string inverter and the external equipment must be disconnected.

## 1.5 Maintenance



1. Before maintenance work, you must first disconnect the AC output side circuit breaker, then disconnect the DC Switch, and wait at least 5 minutes before operating the string inverter.
2. During the maintenance process, try to avoid irrelevant personnel from entering the maintenance site.
3. Please maintain the string inverter under the condition that you are familiar with the contents of this manual and have suitable tools and test equipment.
4. For personal safety, please wear insulating gloves and anti-smashing shoes.



The string inverter must be checked and maintained regularly. For details, please refer to **5 Maintenance and Troubleshooting**.

--End of the chapter--



# 2 Product Description

## 2.1 Product Introduction

EVVO series three-phase string inverters are independently developed by EVOLVE ENERGY GROUP Technology, whose main function is to convert the DC power generated by the PV string into AC power and feed it into the power grid.

EVVO 15 has 2 input interfaces, EVVO 20/25 have 4 input interfaces, and EVVO 30 has 6 input interfaces. They are only suitable for 400VAC low-voltage grid-connected scenarios, such as village-level photovoltaic power stations below 400kW or industrial and commercial rooftop photovoltaic power stations.

### 2.1.1 Schematic Diagram

EVVO 15 accesses 2 PV strings, EVVO 20/25 access 4 PV strings, and EVVO 30 accesses 6 PV strings. There are 2 MPPT circuits inside the inverter to track the MPPT of the strings, and then convert the DC power to three-phase AC power through the inverter circuit. The schematic diagram is shown below.

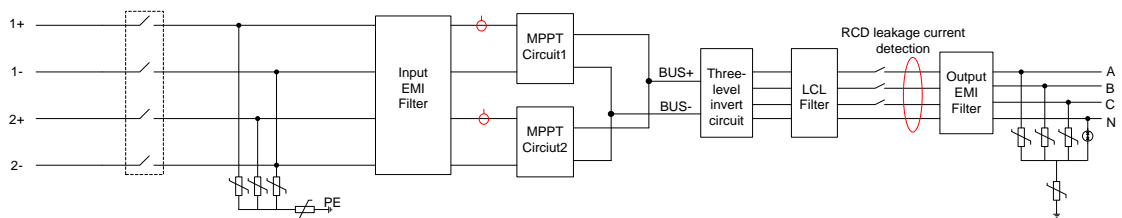

Figure 2-1 System schematic diagram of inverters with 2 inputs

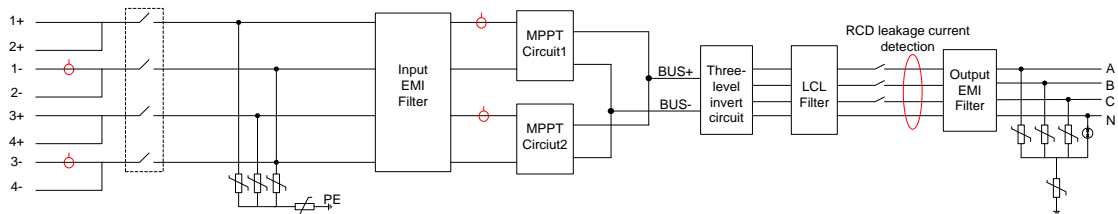

Figure 2-2 System schematic diagram of inverters with 4 inputs

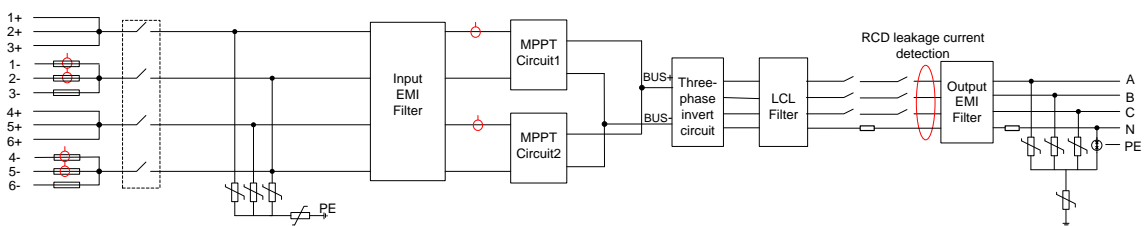

Figure 2-3 System schematic diagram of inverters with 6 inputs

### 2.1.2 Operation Mode

EVVO three-phase string inverter has three working modes: standby mode, operation mode, and shutdown mode. The switching conditions for these three modes are shown as follows.

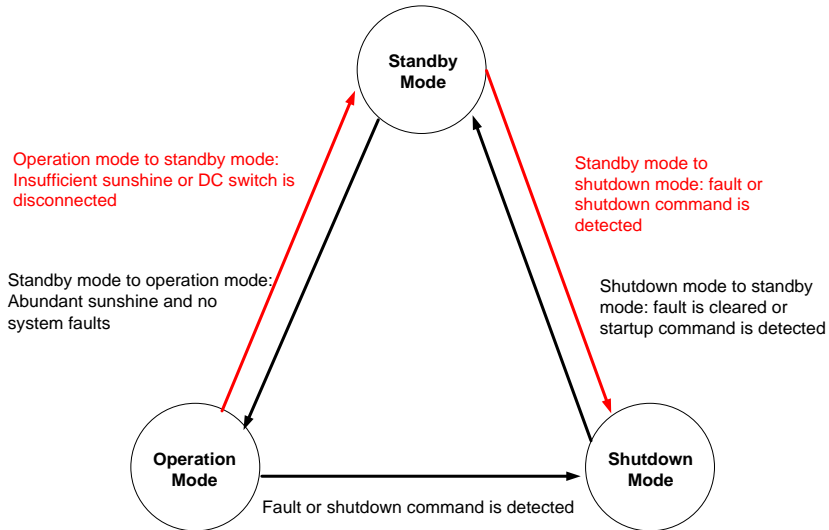

Figure 2-4 EVVO string inverter operation mode

Operating mode	Description
Standby	1) Standby mode mainly means that the external environment does not meet the operating conditions of the inverter such as insufficient light and the disconnection of DC input switch. In this mode, the inverter continuously self-tests and enters the operating mode once the operating conditions are met. 2) In the standby mode, if the inverter detects a shutdown command or finds a fault after the power-on test, it enters the shutdown mode.
Operation	In the operation mode: The inverter converts the DC power of the PV string into AC power and feeds it into the grid. The inverter performs MPPT operation to make the PV string output maximum power. If the inverter detects a fault or a shutdown command, it enters the shutdown mode. If it is detected that the input power of the PV string is lower than the grid-connected power generation condition, it enters the standby mode.
Shutdown	If the inverter detects a fault or a shutdown command during standby or operation, it switches to the shutdown mode. In the shutdown mode, if the inverter detects that the fault has been cleared or a power-on command, it enters the standby mode.

## 2.2 System Configuration and Application

### 2.2.1 Application Description

Figure 2-5 shows the application of the string inverter, and Figure 2-6 shows the networking design scheme of the distributed PV power station.

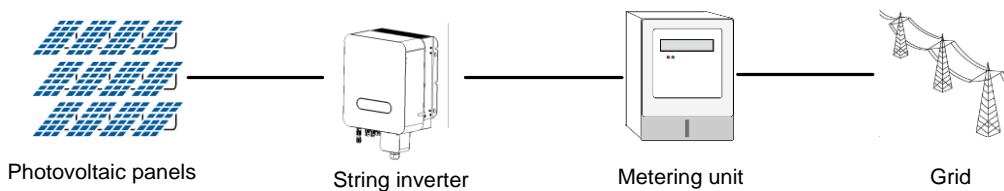

Figure 2-5 Application schematic diagram of string inverter

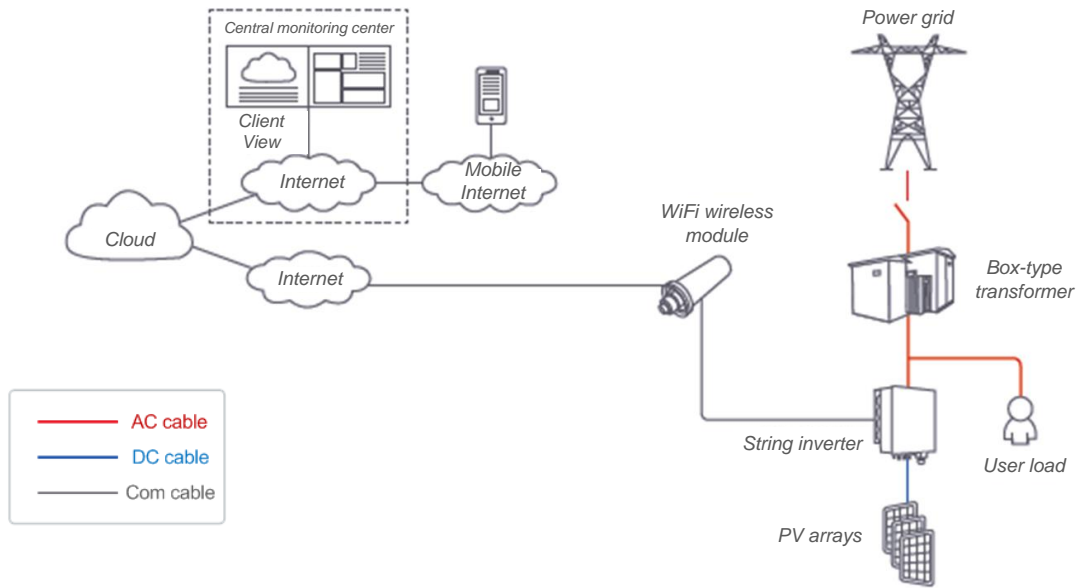

Figure 2-6 Networking scheme of distributed PV power station

### 2.2.2 Supported Grid Form

The power grid forms supported by EVVO 15, EVVO 20 EVVO 25 and EVVO 30 include TN-S, TN-C, TN-C-S, TT and IT.

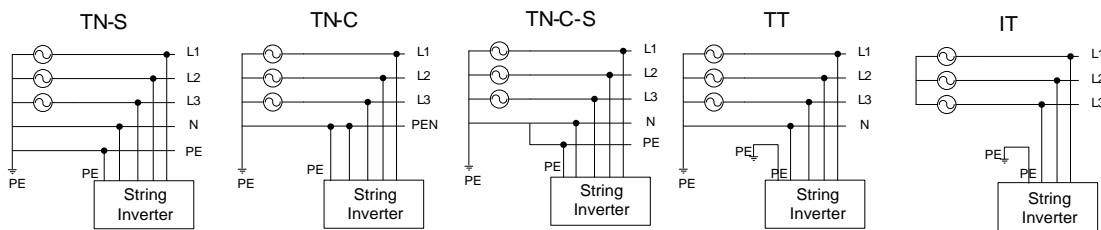

Figure 2-7 Schematic diagram of various power grid forms

### 2.3 Naming Rules

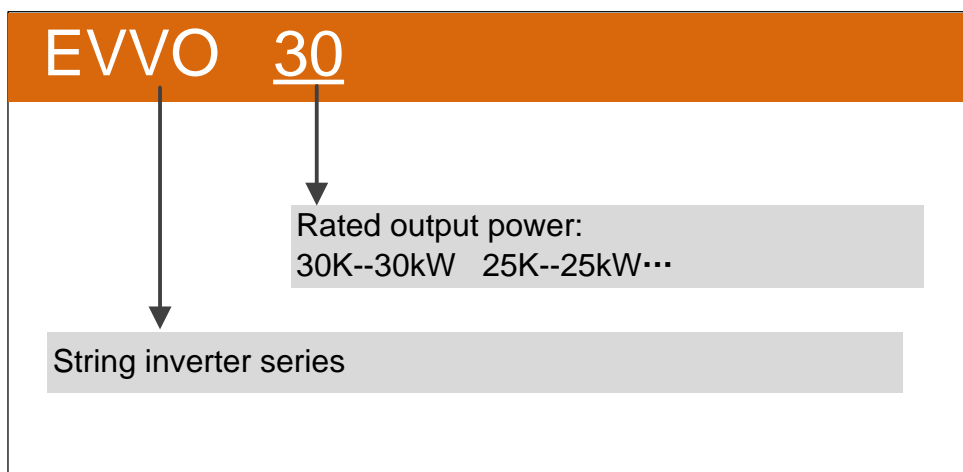



Figure 2-8 Naming rules

## 2.4 Nameplate Label

<b>EVVO</b>	
Product Name	PV Solar Grid Tie Inverter
Model	<b>EVVO 15</b>
Max. DC Input Power	22.5kW
Max. DC Input Voltage	1100Vdc
MPPT Voltage Range	200-1000Vdc
Max. DC Input Current	1×26+1×20Adc
Max. short circuit input current	1×39+1×30Adc
Rated AC Grid Voltage	3L/N/PE 400V
Rated AC Grid Frequen	50/60Hz
Rated AC Output Pow	15kW
Max. Active Power	16.5kW
Max. Apparent Output Pow	16.5kVA
Max. AC Output Current	23.9Aac
Power Factor	-0.8~+0.8
Operating Temperature Range	-40°C~+60°C
Ingress Protection	IP65
Protection Level	Class I
Serial Number	
Manufacturing Date	
	
<b>Safety Warning</b>	
	The AC and DC circuits must be disconnected separately, 5min and the maintenance personnel must wait for 5 minutes before they are completely powered off before they can start working.
	It is strictly forbidden for users to open the casing. Professional maintenance is required for internal maintenance of the inverter.
	Surface high temperature, Please do not touch the inverter case.
	The DC input terminals of the inverter must not be grounded.
	Please read the instructions carefully before use.

 Note: The data is for reference only. For more details, please refer to the physical object or technical agreement of the corresponding product.

## 2.5 Inverter Configuration

This section describes the internal components, back components and bottom interfaces of the string inverter. The bottom structure of different models may be different, and the model of 30K is taken as an example here.

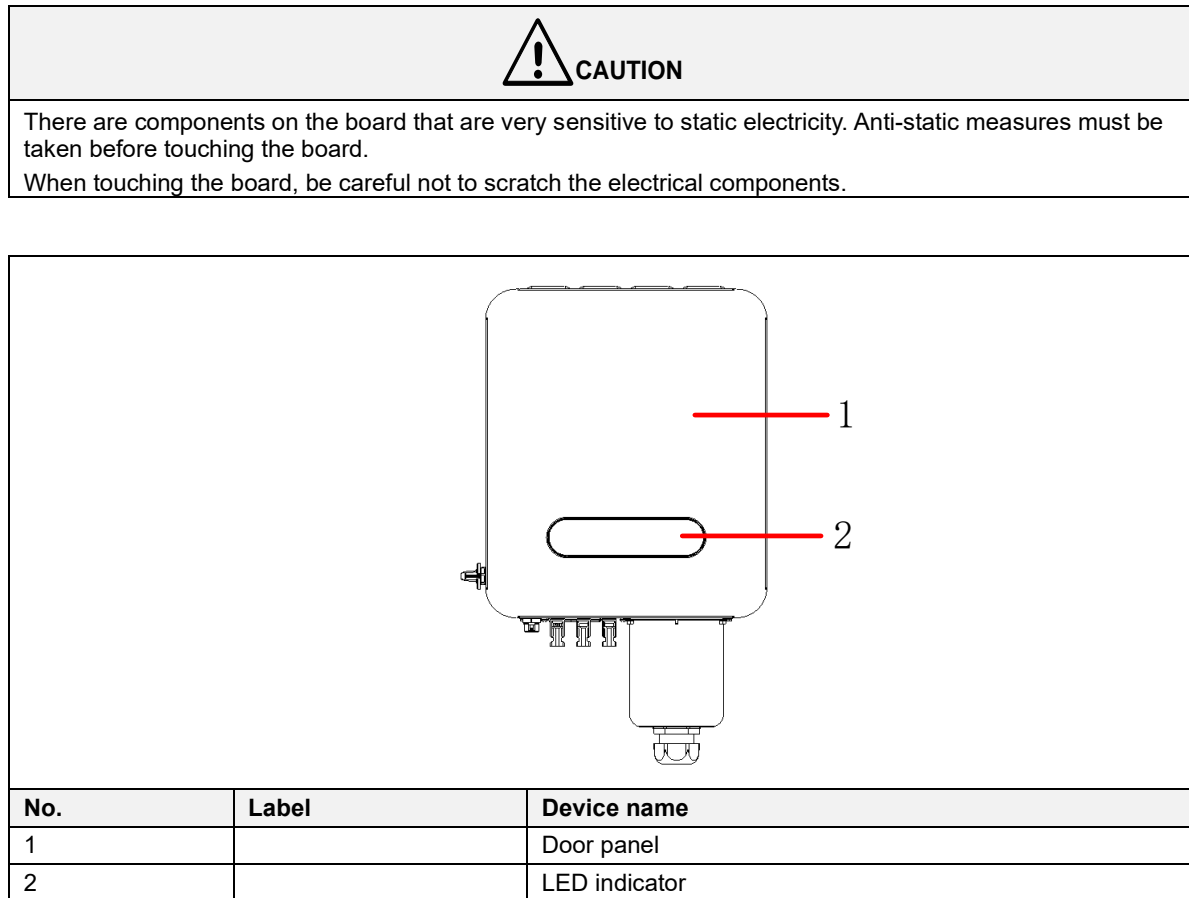
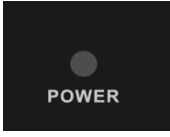
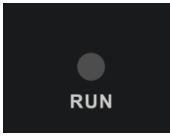
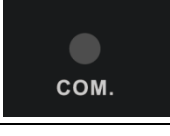
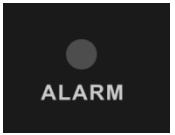

Figure 2-9 Front view of the inverter

The LED indicators from left to right are described as follows:

Table 2-1 LED Indicator Description

Indicator light	Meaning	Status	Description
	PV and grid connection	Blue light on	The PV side and the grid are connected normally
		Blue light fast blinking	The grid is connected normally but the PV side is connected abnormally
		Blue light slow blinking	The PV side is connected normally but the grid is not connected
		Blue light off	Both the PV side and the grid are not connected
	On-grid operation	Blue light on	The inverter is in grid-connected power-on state
		Blue light off	The inverter is neither grid-connected nor powered on
	Communication indication	Blue light quick blinking	Communication normal
		Blue light off	Communication abnormal
	Alarm indication	Red light blinking	Abnormal alarm

		Red light solid on	Fault alarm
<p>Remarks:</p> <p><b>Slow blinking:</b> 1 second on and 2 seconds off in cycles;</p> <p><b>Fast blinking:</b> 0.5 seconds on and 0.5 seconds off in cycles.</p>			

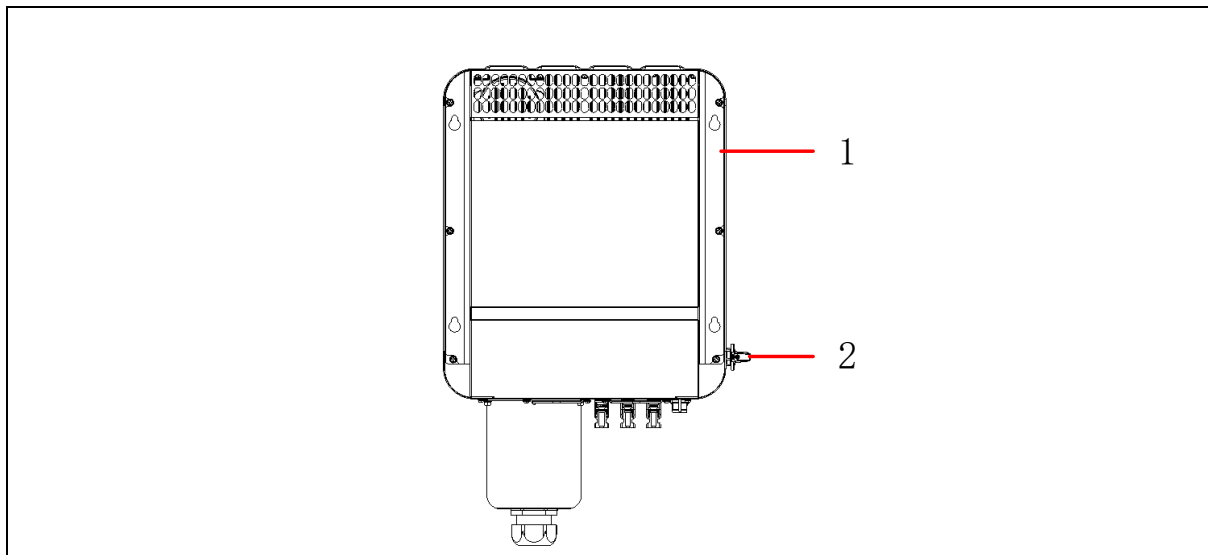

No.	Label	Device name
1		Mounting rack
2		DC Switch

Figure 2-10 Back view of the inverter

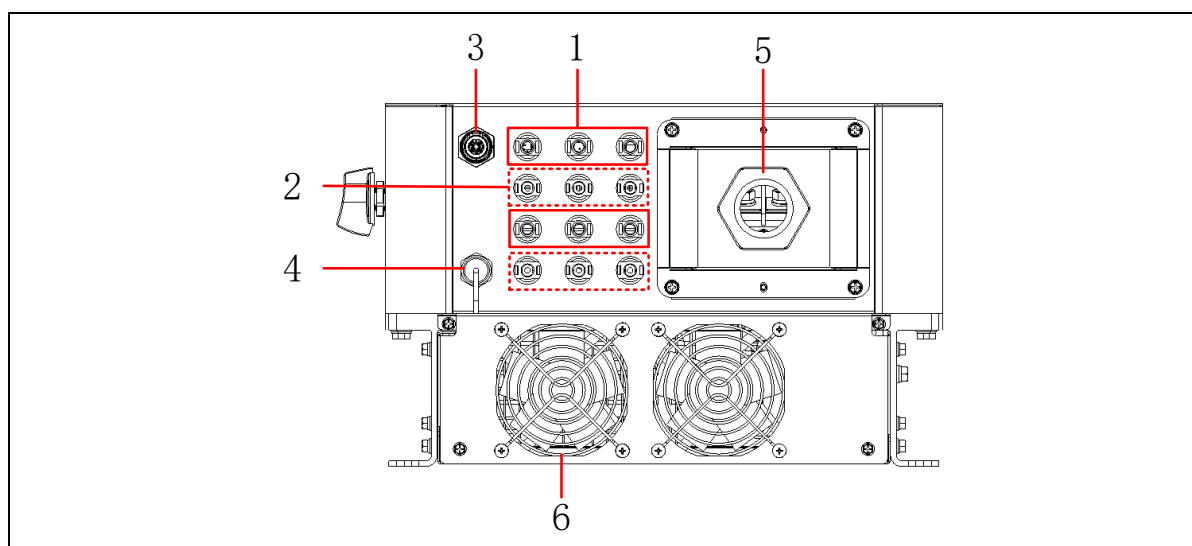

No.	Label	Device name
1	1+ ~ 6+	PV+ terminals
2	1- ~ 6-	PV- terminals
3		Anti-backflow terminal
4		WiFi communication interface
5	AC OUTPUT	AC terminal



6		Fan
---	--	-----

Figure 2-11 Bottom view of the inverter

 Note: EVVO 15 has only 2 PV string inputs at the bottom, EVVO 20/25 have 4 inputs, and EVVO 30 has 6 inputs.

## 2.6 Labels on the Package

On the outer packaging of the product, there are some labels to guide the user to transport and store the product. The meanings indicated by the labels are as follows:

	No stacking		Handle with care. Avoid damage to the converter caused by intense collision and friction in the process of transportation and movement.
	No stepping		Keep dry. Prevent the inverter from getting wet or damp
	Place vertically and no tilting		No rollover
<b>FRONT</b> <b>机柜正面</b>	Front side of the product	<b>BACK</b> <b>机柜背面</b>	Back side of the product

## 2.7 Warning Signs on the Inverter

In order to ensure the personal and property safety of users when using this product and avoid accidents, the following warning labels may be placed inside and outside the string inverter to remind users of safety precautions during operation.

	<b>Protective earthing:</b> PE terminals need to be reliably grounded to ensure the safety of both operation personnel and equipment.
	<b>General warning:</b> This part may have other potential dangers except high voltage danger. Please watch out!
	<b>High voltage danger:</b> This part may have high voltage danger. Please watch out!
	<b>Hot surface:</b> Pay attention to the hot surface to prevent burns.
	<b>Refer to the user manual:</b> Please refer to the corresponding instructions in the user manual before operation.
	<b>Discharge identification:</b> This equipment has an energy storage device. Before maintenance, it is necessary to wait for the energy storage device to discharge to prevent electric shock. The waiting time is not less than the indicated discharge time.

## 2.8 Technical Data

	Model	EVVO 15
<b>DC parameters</b>	Maximum DC voltage	1100V
	Startup voltage	180V
	MPPT voltage range	200V~1000V
	MPPT full load working voltage range	450V~850V
	Maximum input current per MPPT	26A/20A
	Maximum short current	39A/30A
	Maximum input path	2/1
	Number of MPPT	2
<b>AC parameters</b>	Rated output power	15kW
	Maximum active power	16.5kW
	Rated grid voltage	400VAC
	Allowable voltage range	300VAC~520VAC
	Rated output current	21.7A
	Maximum output current	23.9A
	Rated grid frequency	50Hz/60Hz
	Power factor	-0.8~+0.8
	Total harmonic distortion of current	<3%
<b>System parameters</b>	Maximum efficiency	98.60%
	European efficiency	98.10%
	Insulation impedance test	Supported
	Residual leakage current detection	Supported
	String fault detection	Supported
	Output overcurrent protection	Supported
	Protection grade	IP65
	Type of cooling	Smart air cooling
	Night Consumption	< 1W
	Display	LED; WLAN+ APP
	Communication interface	WIFI, Anti-backflow
	DC terminal	MC4 plug-in terminal
	AC terminal	SC terminal & Cable gland

	Model	EVVO 20	EVVO 25	EVVO 30
<b>DC parameters</b>	Maximum DC voltage	1100V		
	Startup voltage	180V		
	MPPT voltage range	200V~1000V		
	MPPT full load working voltage range	425V~850V		
	Maximum input current per MPPT	30A/30A		40A/40A
	Maximum input path	4		6
	Number of MPPT	2		
<b>AC parameters</b>	Rated output power	20kW	25kW	30kW
	Maximum active power	22kW	27.5kW	33kW
	Rated grid voltage	400VAC		
	Allowable voltage range	300VAC~520VAC		
	Rated output current	28.9A	36.1A	43.5A
	Maximum output current	31.8A	39.7A	47.8A
	Rated grid frequency	50Hz/60Hz		
	Power factor	-0.8~+0.8		
	Total harmonic distortion of current	<3%		
<b>System parameters</b>	Maximum efficiency	98.60%		
	European efficiency	98.10%	98.30%	
	Insulation impedance test	Supported		
	Residual leakage current detection	Supported		
	String fault detection	Supported		
	Output overcurrent protection	Supported		
	Protection grade	IP65		
	Type of cooling	Smart air cooling		
	Night Consumption	< 1W		
	Display	LED indicators + APP		
	Communication interface	WIFI, Anti-backflow		
	DC terminal	MC4 plug-in terminal		
	AC terminal	Tube terminal	OT/DT terminal & Cable gland	

## 2.9 Mechanical Parameters

### ➤ Dimension and Weight

Model	W*H*D (mm)	Net weight (kg)
EVVO 15	380*400*247	≤22
EVVO 20	380*450*247	≤25
EVVO 25		≤30
EVVO 30		≤35

📖 Note: Dimension of the inverter here does not contain hangers, handles, pads and other components. Dimensional error: + 10mm.

### ➤ Dimension of the Inverter and Mounting Rack

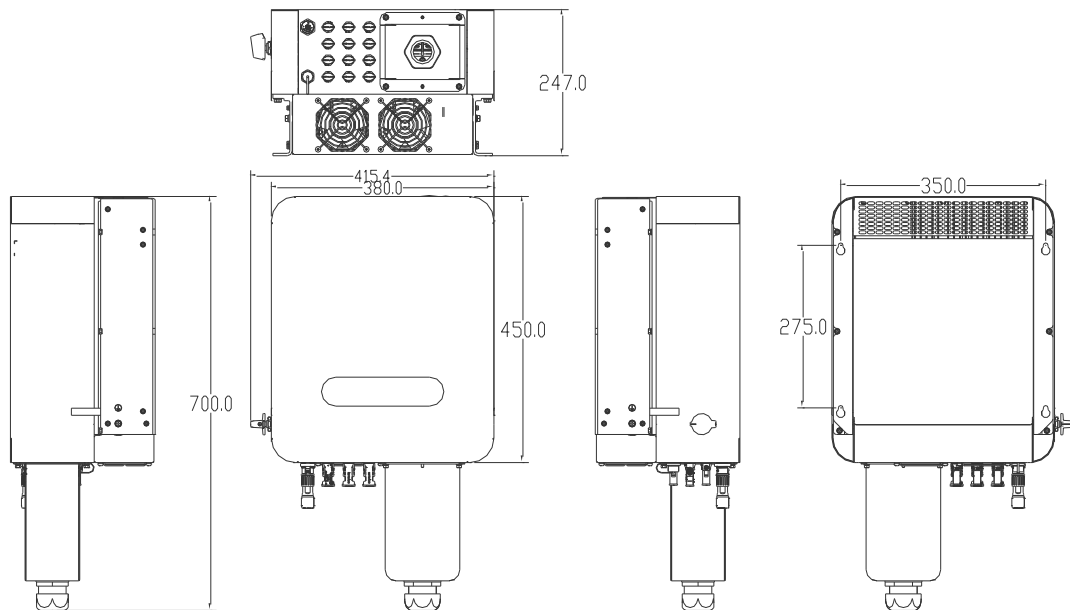

Figure 2-12 Dimensions of the inverter (unit: mm)

📖 Note: The model shown in the picture is 30K. The inverter sizes of other models are similar, but the size of AC cable protection cover may be different.

## 2.10 Ambient Requirements

Transportation environment		Requirements
Type of shipping	Waterways, railways, highways, aviation, etc.	
Ambient temperature	-40°C~+70°C	
Relative humidity	≤95% when the temperature is +40°C	
Mechanical condition	The vibration should not exceed the following limits: 2Hz≤f<9Hz, displacement 7.5mm; 9Hz≤f<200Hz, acceleration 20m/s <sup>2</sup> ; 200Hz≤f<500Hz, acceleration 40m/s <sup>2</sup>	
Storage environment		Requirements
Storage place	Store the product in a warehouse with air circulation, no harmful gases, no flammable or explosive materials, and no corrosive materials. Avoid strong mechanical vibrations and shocks and stay away from strong magnetic fields.	
Ambient temperature	-40°C~+70°C	
Relative humidity	≤95%	
Mechanical condition	The vibration should not exceed the following limits: 10Hz≤f<57Hz, displacement 0.075mm; 57Hz≤f<150Hz, acceleration 10m/s <sup>2</sup>	
Working environment		Requirements
	Normal operation state	Shutdown state
Installation place	Do not install the inverter in an area where flammable or explosive materials are stored. The installation site can be indoors or outdoors, preferably in a well ventilated environment. Avoid direct sunlight, rain and snow to extend the life of the inverter. It is recommended to install it in a sheltered location. If it is not possible, install an awning.	
Ambient temperature	-40°C~+60°C (Derating is required while the temperature is above 45 °C)	-40°C~+70°C
Relative humidity	Relative humidity: 0%~100%, internal condensation is not allowed.	
Altitude	≤4000m; derating is required when the altitude is above 3000m.	
Mechanical condition	The vibration should not exceed the following limits: 10Hz≤f<57Hz, displacement 0.075mm; 57Hz≤f<150Hz, acceleration 10m/s <sup>2</sup> .	

--End of the chapter--

# 3 System Installation

## 3.1 Unpack and Inspect

After confirming that the outer packaging is intact, please carry out the unpacking inspection. Unpack the packaging box and check whether the appearance of the string inverter is in good condition. When opening the package, please use tools carefully to avoid scratching the string inverter.

Although the inverter has been strictly tested and inspected before leaving factory, accidental damage might happen during transportation. Please inspect and check the product as soon as you receive it. If there is any damage or omission, please contact us and we will help you as soon as possible.

## 3.2 Installation Tool Preparation

Tool or device	Purpose	Remarks
4#Inner hexagon spanner	Disassemble and assemble of the lower door panel of the inverter	
Phillips screwdriver (PH2)	Fasten the grounding screws and screws of mounting plates	Bolt specifications: M6 and M8
Tube type crimping pliers	Crimp the communication cable terminals	
Socket wrench	Wire the output cable	Bolt specifications: M8
MC4 crimping pliers	Crimp the MC4 terminals	The input cable needs to be crimped into the MC4 terminal before it can be connected to the PV+/PV- terminal on the inverter
MC4 removal tool	Remove MC4 terminal	
Wire stripper	Strip wire	
Multimeter	Measure voltage to ensure wiring and installation safety	
Safety equipment	Necessary labor protection	Insulating shoes, gloves, etc

## 3.3 Installation Environment Requirements

- The environmental requirements for the installation of string inverter are described in "**1 Safety Precautions**".
- The installation method and position must be suitable for the weight and dimension of the string inverter. See "**2.9 Mechanical Parameters**".
- The string inverter should be installed in a well ventilated environment for heat dissipation. As direct sunlight, rain and snow shortens the life of the inverter, it is recommended to choose sheltered installation sites. If that cannot be satisfied, please set up a sun shading shelter (optional accessory).
- During the operation of the string inverter, the temperature of the chassis and the radiator will be relatively high. Do not install the inverter in the position which will be touched unintentionally.

 Note: This chapter takes EVVO 30 as an example to introduce the cable connection methods for installation. The interfaces of other models may be different, so please connect cables according to actual situation while referring to this chapter.

### 3.4 Reserved Space Requirement

When installing the string inverter, suitable space must be reserved around it for heat dissipation and maintenance.

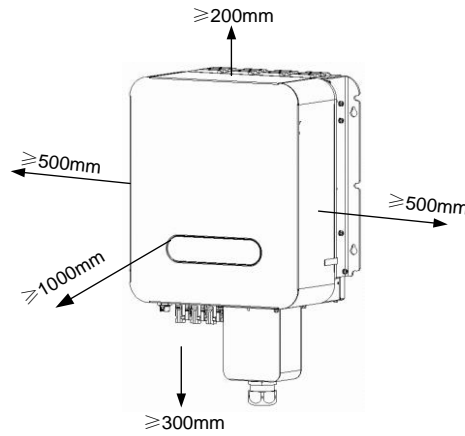

Figure 3-1 Reserved space requirements

If multiple inverters are installed at the same height, the side-by-side installation is recommended.

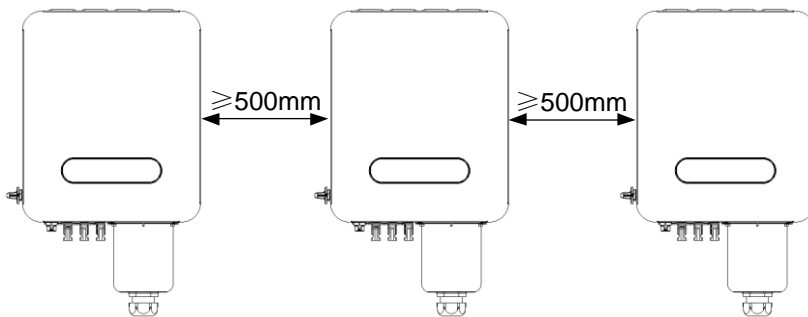

Figure 3-2 Side-by-side installation space

If multiple inverters are required to install in two rows, the triangle installation is recommended.

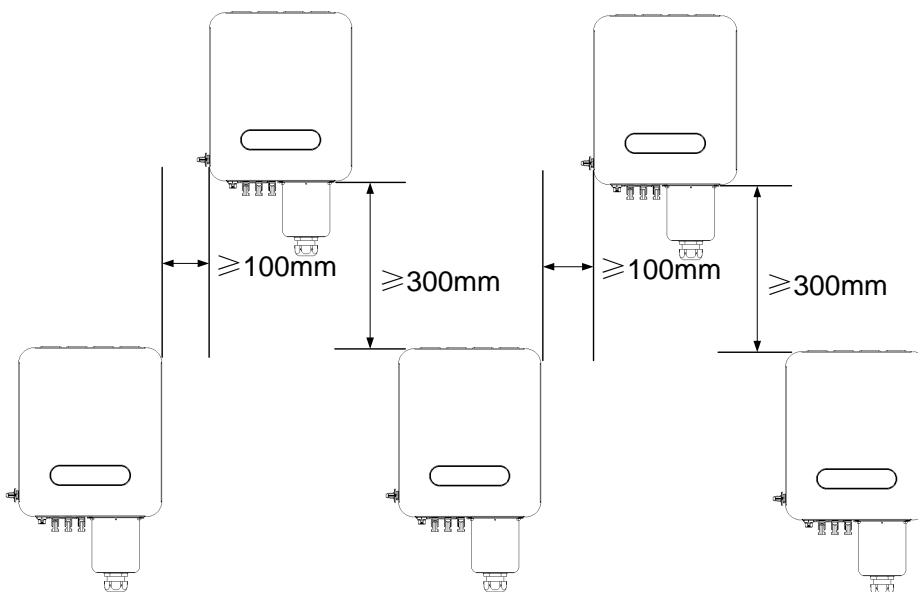

Figure 3-3 Triangle installation space



## 3.5 Installation Method



1. Please refer to **1 Safety Precautions** for precautions during inverter installation. For installation environment requirements, please refer to **3.3 Installation Environment Requirements**.
2. During installation, it must be confirmed that the site installation position can bear the total weight of the inverter and accessories to avoid falling during installation or use.
3. It is recommended that two people work together to fix the inverter to avoid mechanical injury. During installation, safety measures shall be taken to prevent injuries.
4. Please install it vertically or tilt it back 15 ° at most to facilitate heat dissipation of the machine. Do not tilt the inverter (tilt forward, tilt back too much, roll), horizontally or upside down.
5. If it is impossible to avoid direct sunlight, please add a sunscreen.

### ➤ Installation steps

Before installing the inverter, check whether the delivery is complete. There should be: the inverter\*1; accessories\*1 set; AC wiring cover\*1; mounting plate\*1.

1. Take out the mounting plate and the mounting bracket.

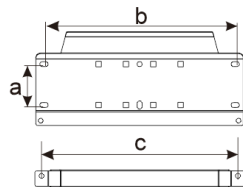

Power Range	a	b	c
15kW	50mm	306mm	335mm
20~30 kW	75mm	350mm	350mm

2. Install the mounting bracket to the inverter.

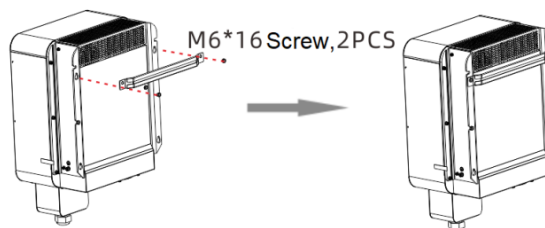

3. Install the mounting plate to the wall or the bracket.

Drill holes on the wall (diameter: 10mm; depth: 80mm)

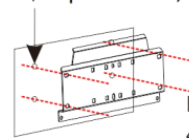

Wall mounting

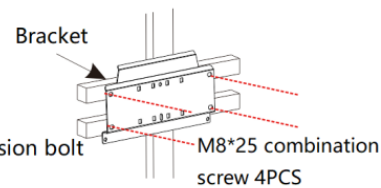

Bracket mounting

4. Hang the mounting bracket of the inverter to the mounting plate and fix it with screws to prevent it from shaking.

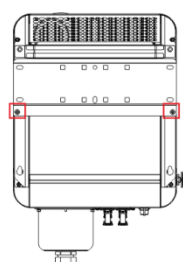
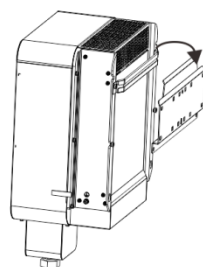

Combination screw:  
M6\*16, 2PCS

### 3.6 Electrical Connections

#### 3.6.1 Cable Requirements

The choice of cable should comply with relevant national standards and meet the load requirements.

**Power cable requirements**

Please refer to the electrical data of the product, and then comprehensively consider the ambient temperature, current, margin as well as other relevant factors to select the cable.

**Communication cable requirements**

Since weak communication signals are susceptible to external interference, it is necessary to adopt communication cables with shielding layers, and the shielding layer should be grounded reliably. You can refer to the relevant document of *GB 50217-2007 Cable Design Specification*.

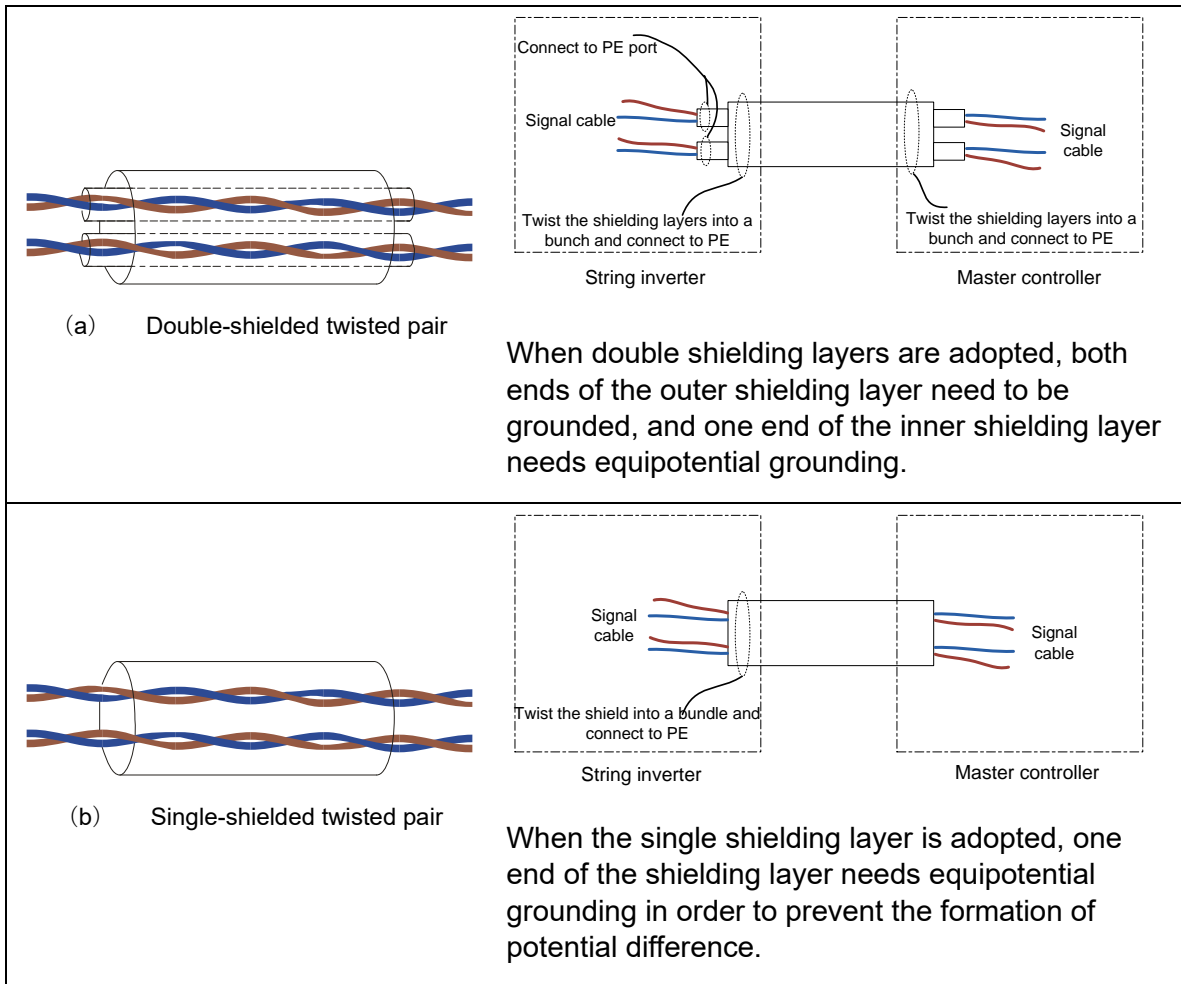

Figure 3-4 Twisted pair with shielding layer

#### 3.6.2 Cable Selection

Name	Recommended Cable Specifications
PV DC branch cable	Industry general PV cable, model: PV1-F It is recommended to use copper cables with the cross-sectional area of 4.0mm <sup>2</sup> -6.0mm <sup>2</sup> for each PV+ and PV- branch.

Name	Recommended Cable Specifications			
AC side cable	Model	Recommended cross-sectional area of the 4-core copper cable (S)		Recommended cross-sectional area of the 4-core aluminum cable
	15kW	10~16mm <sup>2</sup>		/
	20kW	16~25mm <sup>2</sup>		/
	25/30kW	25~50mm <sup>2</sup>		35~50mm <sup>2</sup>
PE cable	Recommended cross-sectional area of the cable: Products with power of 15kW: not less than 16mm <sup>2</sup> Products with power of 20/25/30kW: not less than the maximum between S/2 and 16mm <sup>2</sup>			
AC side terminal type and suitable wire size	Model	AC output terminal type	Outer diameter of the AC cable, mm (including insulation skin)	Width of the AC terminal
	15kW	SC	13 ≤ φ ≤ 20	≤12.5mm
	20kW	Tube terminal	18 ≤ φ ≤ 25	/
	25/30kW	DT/OT	22 ≤ φ ≤ 32	≤23.5mm

### 3.6.3 Torque Requirement

When tightening cable connections, the tightening torque needs to meet the requirements of the following table.

Table 3-1 Torque requirements for cable connection

Thread specification	Performance level 4.8		Performance level 8.8		Unit
	General Connection	High tightness connection	General Connection	High tightness connection	
M3	6	8			kgf.cm
M4	12	14			kgf.cm
M5	25	30			kgf.cm
M6	50	60			kgf.cm
M8			110	150	kgf.cm
M10			300	390	kgf.cm
M12			550	650	kgf.cm
M16			1600	2000	kgf.cm

 Note: Inside the string inverter, the bolts with the nominal diameter of the external thread above 8mm are 8.8 Dacromet bolts.

### 3.6.4 Preparation before Operation

 DANGER	
1.	When connecting cables, do not operate when the product is energized and please follow the relevant requirements in <b>1 Safety Precautions</b> .
2.	Before connecting the cables, please complete the following preparations to avoid personal injury. <ol style="list-style-type: none"> <li>1) Before electrical connections, please make sure that the "DC SWITCH" of the inverter is in the "OFF" state, otherwise the high voltage of the inverter may cause a shock hazard.</li> <li>2) Determine the positive and negative poles of the input cable and mark them, and make sure that the input cable is disconnected from the PV string.</li> <li>3) Please confirm that the open circuit voltage of the PV string does not exceed the specified limit.</li> </ol>
3.	When connecting the input cable, please make sure that the positive and negative terminals of the input cable correspond to the positive and negative terminals of the PV inverter of the string inverter.

### 3.6.5 Connect the PE Cable

Please connect the inverter to the grounding bar through the PE cable to achieve the grounding protection. The PE mark is affixed to the PE terminal. The cross-sectional area of the PE cable is not less than 16mm<sup>2</sup> (copper wire) and the bolt specification is M6.

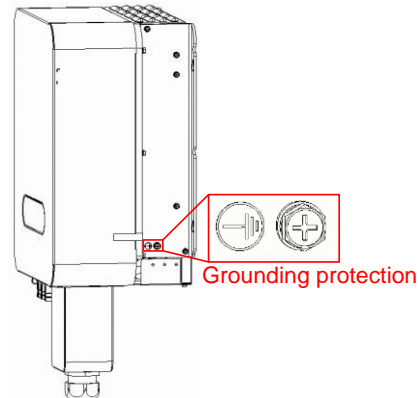

Figure 3-5 Grounding protection

For the grounding of multiple string inverters, please use single-point grounding instead of winding the ground wire into a ring shape as shown below.

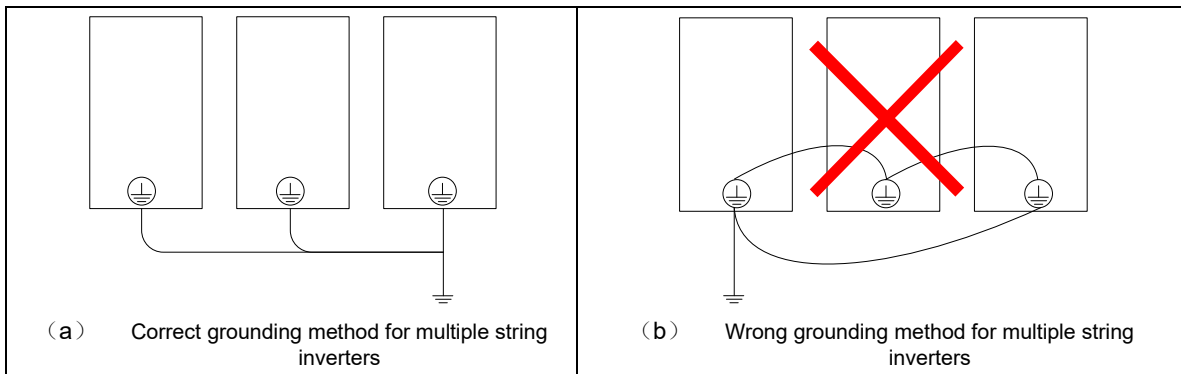

Figure 3-6 PE connection of multiple string inverters

### 3.6.6 Connect the AC Output Cable

#### ➤ Matters needing attention

- An independent three-phase circuit breaker must be configured outside the AC side of each inverter to ensure reliable disconnection of the inverter from the grid. And the circuit breaker specifications should meet the technical requirements.
- It is forbidden for multiple inverters to share one circuit breaker.
- It is forbidden to connect the load between the inverter and the circuit breaker.
- Users should prepare cables with appropriate cross-sectional area according to different models (please refer to "**3.6.2 Cable Selection**" for more details).

#### ➤ Operation steps

- (1) Remove the cable protection cover, and then unscrew the locking cap of the gland.
- (2) Pass four 10mm<sup>2</sup> cables through the locking cap and gland, and then connect them to A, B, C, and N of the AC wiring terminal block in turn. Twist the shielding layer of the AC cable into a bundle and connect it to the PE. The following figure takes the 30K as an example. For other models, please refer to the actual situation.
- (3) Install the cable protection cover, and then tighten the gland.

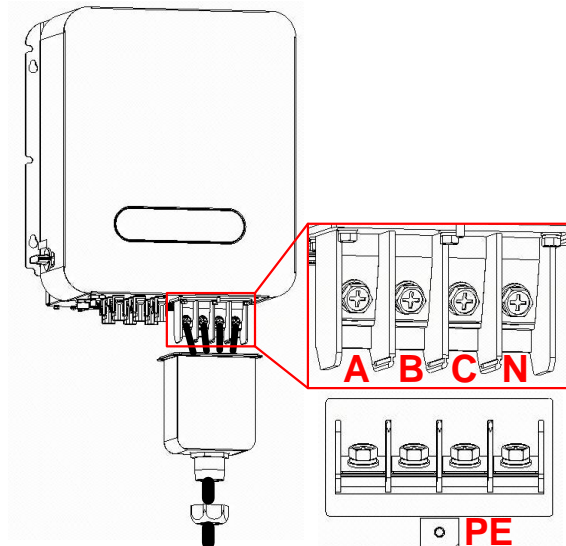

Figure 3-7 AC side cable connection

### 3.6.7 Connect the Communication Cable

#### ➤ Selection of communication method

The inverter supports anti-backflow interface and RS485 communication.

#### ➤ Connecting the cables

##### Connect RS485 cables

- 1) Take out the anti-backflow communication terminal from the accessories and then insert the communication cable whose terminal has been crimped and reinforce them with bolts.

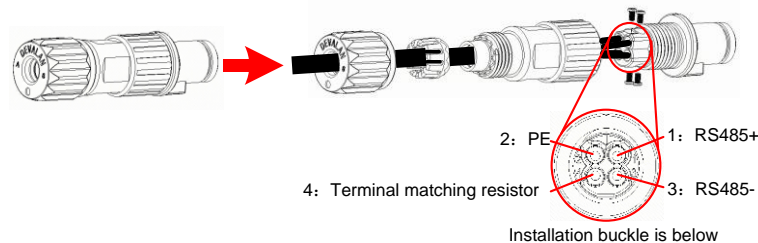

Figure 3-8 Connect cables to the terminal

**Note:** If the communication distance exceeds 300m or the field communication quality is poor, the terminal matching resistors of the last inverter shall be short-circuited by short-circuiting the PIN1 and PIN4 of the last inverter's communication terminal.

- 2) After reassembling the communication terminal, insert it into the anti-backflow communication interface and make sure that the connection is reliable.

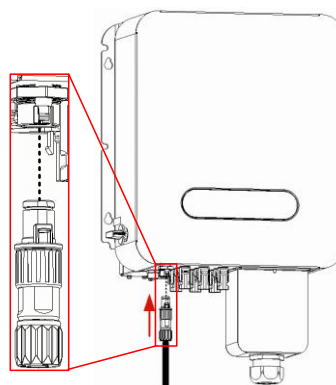

Figure 3-9 Connect the terminal to the inverter

### WIFI communication module connection

Connect the WIFI module configured in the delivery accessories to the 4-pin terminal of the inverter, and make sure that the connection is reliable.

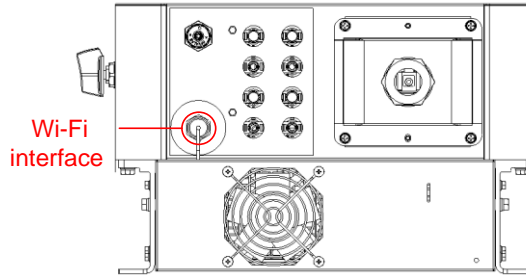



Figure 3-10 Location of the Wi-Fi interface

### 3.6.8 Connect the DC Input Cable

In order to make full use of the DC input power, the PV strings of the same input MPPT should be identical in structure, including the same model, the same number of panels, the same tilt angle, and the same azimuth.

 <b>DANGER</b>
<ol style="list-style-type: none"><li>1. When the sun shines on the battery panel, it will generate voltage which may cause life-threatening dangers. Therefore, if the DC input line is connected under light conditions, you need to ensure that the input line is not charged (you can cover the panel with an opaque cloth and then proceed operating).</li><li>2. Before connecting the input cable, make sure that the DC side voltage is within the safe voltage range which is within 60VDC, and the DC switch is in the "OFF" state, otherwise the high voltage generated may cause a shock hazard.</li><li>3. When the inverter is running in the grid, it is forbidden to perform maintenance operations on the DC input cable, otherwise it will cause electric shock hazard.</li><li>4. If you want to remove the positive and negative connectors, make sure that DC switch has been placed in the "OFF" state and there is no current output from the PV branch.</li></ol>

 <b>WARNING</b>
<p>Please ensure that the following conditions are met, otherwise it may cause a fire hazard.</p> <ul style="list-style-type: none"><li>• Each serially connected component of the string is of the same specification and model.</li><li>• The maximum opening voltage of each PV string cannot be greater than 1100VDC under any circumstances.</li><li>• The maximum short-circuit current of each PV string should not exceed 30A under any conditions.</li><li>• Ensure that the polarity input on the DC input side is correct, that is, the positive pole of the PV module is connected to the positive pole of the DC input terminal of the inverter, and the negative pole is connected to the negative pole of the DC input terminal of the inverter.</li></ul>

➤ Precautions for grounding the PV string

If the inverter is directly connected to the power grid in which the neutral cable and the PE cable are connected, the positive or negative pole of the PV string is prohibited from being grounded, otherwise the inverter cannot work normally.

➤ Steps of crimping MC4 terminal

The input cable needs to be crimped into the MC4 terminal for connection to the string inverter PV+/PV- terminals. Before operation, make sure that 3.6.4 Preparation before Operation has been completed.

1. Ensure that the positive and negative poles of the input cable are determined and identified.

 Note: Please do not judge the positive and negative poles according to the cable color in this manual. Be sure to take the actual measurement as the standard.

2. Strip the wire with a wire stripper.

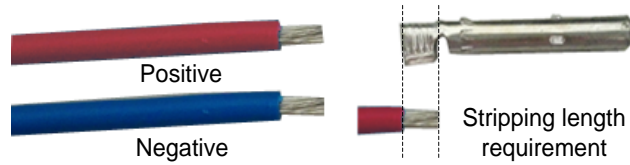

Figure 3-11 Strip wire

3. According to the correct polarity, crimp the cable to the corresponding core.

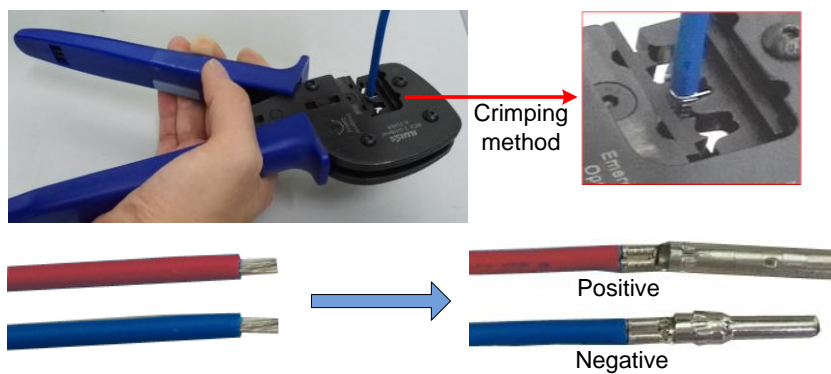

Figure 3-12 Crimp terminals

4. Insert the core into the male and female ends of the MC4 connector according to the correct polarity, and tighten the connector back cover.

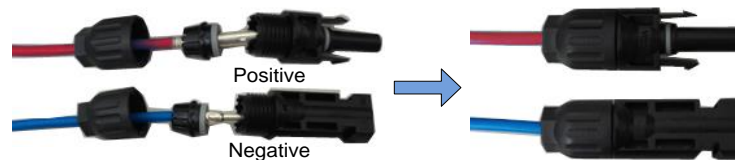

Figure 3-13 Assemble the connector

➤ Insert MC4 terminal

Insert the positive and negative connectors into the positive and negative poles of the DC input terminal respectively until you hear a “click”, which indicates that the terminal is stuck in place.

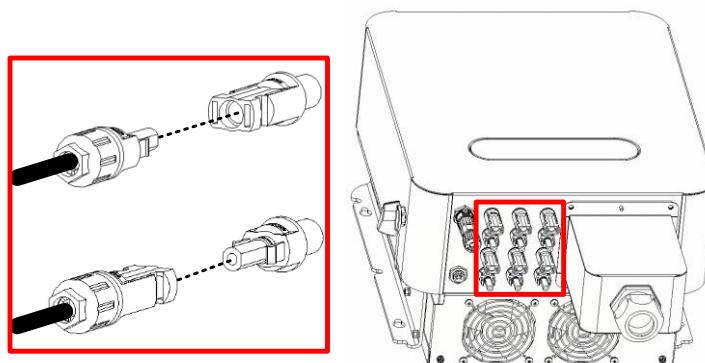

Figure 3-14 Connect DC terminals



Please use the MC4 terminals configured in the delivery accessories of the inverter. Device damage due to incompatible MC4 terminals is not covered by the warranty.

After the cable connection of the string inverter is completed, check if there is a gap at the cable gland. If there is, use fireproof mud to block the gap. If there are unconnected input terminals, seal them well.

--End of the chapter--



# 4 Commissioning Guide

## 4.1 Check before Power On



- Before powering on the inverter, please read "1 Safety Precautions" carefully and do a detailed check according to the table below.
- Before operating or maintaining the internal metal parts, please use multimeter to measure their voltage to the enclosure (protective earthing) in order to avoid any danger.

After the inverter is installed, the following items need to be checked carefully before power on.

### Mechanical inspection

- Please read "1 Safety Precautions" carefully.
- Ensure that the environmental safety of the string inverter.
- Check if there are any foreign objects left inside and on the top of the string inverter cabinet.
- Ensure that the string inverter has enough space reserved around for maintenance and heat dissipation.
- The cables are marked clearly and correctly.
- Check if there any condensation inside the string inverter. If there is, remove it with heating tools.
- Ensure that all wiring screws are tightened according to torque requirements.
- Ensure RS485 wiring is correct and reliable.
- Make sure there is no gap between the input terminal and the cable gland.

### Electrical inspection

- Ensure that the connection of the string inverter is reliable and the polarity is correct.
- The power cables and signal cables are all in conformity with the electrical safety regulations.
- Uses of terminals for signal cables and power cables are correct.
- The isolation area and warning signs have been set up around the string inverter to prevent others from misoperation or proximity.

## 4.2 System Power On

After the electrical connection is completed, the inverter can be powered on.

**Step 1:** Set the DC SWITCH of the inverter to the "ON" state.

**Step 2:** Close the AC circuit breaker between the inverter and the power grid.

After performing the above steps, if the system has no faults and meets the startup requirements, the inverter will start.

## 4.3 System Power Off

### ➤ Precautions

- After the inverter is powered off, there will be residual electricity and residual heat on the enclosure, which may cause electric shock or burns. Therefore, please wait at least 5 minutes before you operate the inverter.

- When powering off the system, please follow the operation instructions and safety regulations in this chapter.
  - Step 1:** Issue the shutdown command to the inverter through the data collector or near-end APP software.
  - Step 2:** Disconnect the circuit breaker between the inverter and the power grid.
  - Step 3:** Set the DC SWITCH of the inverter to the “OFF” state.

--End of the chapter--

# 5 Maintenance and Troubleshooting

## 5.1 Maintenance Items and Cycles

 <b>DANGER</b>	
<ol style="list-style-type: none"> <li>1. Please read <b>1 Safety Precautions</b> carefully before maintenance, and use a multimeter and other relevant instruments to detect the voltage between the metal parts that need to be or maybe touched and the grounding copper bars so as to avoid electric shock.</li> <li>2. During maintenance, please pay attention to the warning labels of the string inverter to avoid personal injury due to high voltage.</li> <li>3. During maintenance, please make sure that the DC Switch is in off state, and the circuit breaker between the inverter and the grid is disconnected.</li> <li>4. After the maintenance, close the DC input switch of the inverter and the circuit breaker between the inverter and the grid.</li> </ol>	

String inverters need to be regularly maintained. Common maintenance items and cycles are shown in the table below.

Table 5-1 Maintenance items and cycles of the string inverters

Parts	Item	Description	Solutions	Maintenance Cycle
Overall inspection	Appearance	Observe whether the inverter appearance is damaged or deformed.	Please replace it in time when it is serious.	Once every six months to one year
	System cleaning	Check if there are dusts and foreign matters on the surface of the inverter.	Clean up the foreign matters and dusts.	
		The heat sink is covered with dust and dirt.	Remove occlusion and clean dusts	
System running	Operating state	Check if there is any abnormal noise while the inverter is running.	If the problem is serious, please replace it in time.	Once every six months to one year
	Operating parameters	When the inverter is running, check whether the parameters are set correctly.	Troubleshoot abnormal settings	
Connection parts	Fall off or loose	Check if the cable connection is disconnected or loose.	Tighten connections as specified	Once every six months to one year
	Damage	Check if there is any damage on the cable. Especially check the surface of the cable that is in contact with the metal surface for traces.	If the problem is serious, please replace it in time.	
	Terminal	Check if the waterproof covers of the unused RS485, RJ45 or other terminals are locked tightly	Ensure that they are sealed well.	

 **Note:** Before wiping the heat sink, power off the inverter normally and disconnect the circuit breaker between the inverter and the grid, and then set the DC switch of the inverter into the OFF state. After powering off, wait at least 5 minutes before wiping the heat sink so as to avoid accidents.

## 5.2 Troubleshooting

### ➤ Boost Side

Fault word	ID	Fault/alarm name	Fault/alarm cause	Troubleshooting
Fault word 1	0	Auxiliary power failure	$\pm 12V$ of the auxiliary power supply is too high or too low	1. Check whether it can work normally after reset. 2. If it occurs frequently, please contact the EVOLVE ENERGY GROUP technician.
	2	Output hardware overvoltage	The output voltage exceeds the protection point set by the hardware.	1. Check whether it can work normally after reset. 2. If it occurs frequently, please contact the EVOLVE ENERGY GROUP technician.
	3	Hardware overcurrent (secondary)	Unit inductor current is too large	1. Check whether it can work normally after reset. 2. If it occurs frequently, please contact the EVOLVE ENERGY GROUP technician.
	4	Unit 1 hardware overcurrent	Unit 1 current overcurrent and reaches the hardware wave-by-wave current limit time	1. Check whether it can work normally after reset. 2. If it occurs frequently, please contact the EVOLVE ENERGY GROUP technician.
	5	Unit 2 hardware overcurrent	Unit 2 current overcurrent and reaches the hardware wave-by-wave current limit time	1. Check whether it can work normally after reset. 2. If it occurs frequently, please contact the EVOLVE ENERGY GROUP technician.
Fault word 2	2	EEPROM parameters back to default values	EEPROM read and write error	Fault reset or power off
	3	Historical fault storage failed	Historical fault storage failed	Fault reset or power off
	12	Input polarity reverse	Input polarity reverse	Check whether the polarity of the connection is reversed
	13	Insulation fault of the positive bus to the ground	Abnormal insulation impedance of the positive bus to the ground	Check whether the positive bus has grounding fault
	14	Insulation fault of the negative bus to the ground	Abnormal insulation resistance of the negative bus to the ground	Check whether the negative bus has grounding fault
Alarm word 1	6	Boost side alarm	Boost unit open circuit	Please contact the EVOLVE ENERGY GROUP technician.
	7	Boost side short circuit alarm	Boost unit short circuit	Please contact the EVOLVE ENERGY GROUP technician.
	8	Abnormal alarm of battery string	Abnormal battery string	1. Check whether the battery string configuration is abnormal 2. Check whether the access of the battery board is abnormal 3. Check whether the current sampling of the battery string is abnormal
	9	Insulation alarm of the positive bus to the ground	Abnormal insulation impedance of the positive bus to the ground	Find out the cause of abnormal impedance
	10	Insulation alarm of the negative bus to the ground	Abnormal insulation impedance of the positive bus to the ground	Find out the cause of abnormal impedance

## ➤ Inverter Side

Fault word	ID	Fault/alarm name	Fault/alarm cause	Troubleshooting
System fault status word	0	RAM self test failed	Check RAM chip read and write error	1. Check whether it can work normally after reset 2. If it occurs frequently, please contact the EVOLVE ENERGY GROUP technician
	1	EEPROM parameters back to default values	Add EEPROM parameter list and upgrade the code again. After initialization, the default value is different from that in EEPROM	1. Check whether it can work normally after reset 2. If it occurs frequently, please contact the EVOLVE ENERGY GROUP technician
	2	EEPROM read and write failed		1. Check whether it can work normally after reset 2. If it occurs frequently, please contact the EVOLVE ENERGY GROUP technician
	3	FPGA version does not match	FPGA version does not match with that of DSP	1. Check whether it can work normally after reset 2. If it occurs frequently, please contact the EVOLVE ENERGY GROUP technician
	5	Internal communication failure	Internal communication failure	1. Check whether it can work normally after reset 2. If it occurs frequently, please contact the EVOLVE ENERGY GROUP technician
Hardware fault status word	0	Hardware overcurrent (secondary)	Inductor current peak exceeds hardware protection threshold	1. Check whether it can work normally after reset 2. If it occurs frequently, please contact the EVOLVE ENERGY GROUP technician
	3	Grid side hardware overcurrent	Phase A inductor current triggers wave-by-wave current limit protection	1. Check whether it can work normally after reset 2. If it occurs frequently, please contact the EVOLVE ENERGY GROUP technician
	6	Busbar hardware overvoltage	Bus voltage exceeds hardware overvoltage threshold	1. Check whether it can work normally after reset 2. If it occurs frequently, please contact the EVOLVE ENERGY GROUP technician
	7	Busbar midpoint overvoltage	Bus midpoint voltage exceeds hardware overvoltage threshold	1. Check whether it can work normally after reset 2. If it occurs frequently, please contact the EVOLVE ENERGY GROUP technician
Grid fault status word	0	Grid overvoltage	The grid voltage exceeds the overvoltage point set by the system	Confirm whether faults such as box transformer tripping occur at the AC side at the time of fault
	3	Grid undervoltage	The grid voltage is lower than the undervoltage point set by the system	Check whether the inverter has a phase loss or whether the box change contacts are suitable.

Fault word	ID	Fault/alarm name	Fault/alarm cause	Troubleshooting
	6	Grid abnormality	Grid frequency and voltage exceed system setting range	1. Confirm whether the access to the grid is the nominal grid of the inverter; 2. Confirm whether the grid is connected
	7	Grid voltage imbalance exceeds limit	Grid voltage imbalance exceeds system threshold	Check whether the grid is abnormal
	8	Grid overfrequency	The grid frequency exceeds the overfrequency point set by the system	1. Confirm whether the box transformer tripping and other faults occur on the AC side of the inverter through fault recording and event recording 2. Confirm whether the frequency range and the time setting is reasonable
	9	Grid underfrequency	The grid frequency is lower than the underfrequency point set by the system	1. Confirm whether the box transformer tripping and other faults occur on the AC side of the inverter through fault recording and event recording 2. Confirm whether the frequency range and the time setting is reasonable
	11	Island effect protection	Grid voltage loss	Detect the causes of grid voltage loss, such as box transformer tripping, etc.
	13	Grid voltage anomaly	Sudden change of grid voltage	Check if the grid is normal
	14	Low voltage ride through protection	Grid voltage exceeds LVRT protection threshold	Check if the grid is normal
	15	High voltage ride through protection	Grid voltage exceeds HVRT protection threshold	Check if the grid is normal
Inverter fault status word	0	Grid side software overcurrent	Inductor current effect value exceeds protection threshold	Reset the fault
	3	Module current imbalance	Three-phase current imbalance exceeds the threshold	Reset the fault
	5	Module temperature is too high	The radiator temperature is higher than the protection threshold.	Check whether the spoiler fan is normal
	6	High temperature inside the machine	Ambient temperature is higher than protection temperature.	Check whether the spoiler fan is normal
	9	Residual current abnormal	Residual current exceeds the limit	1. If it happens accidentally, it may be caused by the accidental abnormality of the external line. After the fault is cleared, it will resume work without manual intervention. 2. If it occurs frequently or cannot be recovered for a long time, please check whether the ground impedance of the PV string is too low.
Bus fault status word	1	Bus operation short circuit	Bus voltage sag exceeds limit	1. Check whether it can work normally after reset 2. If it occurs frequently, please contact the EVOLVE ENERGY GROUP technician

## 5 Maintenance and Troubleshooting

Fault word	ID	Fault/alarm name	Fault/alarm cause	Troubleshooting
	5	Bus operation over voltage	The bus voltage exceeds the set threshold	1. Check whether it can work normally after reset 2. If it occurs frequently, please contact the EVOLVE ENERGY GROUP technician
	6	Bus operation under voltage	The bus voltage is below the set threshold	1. Check whether it can work normally after reset 2. If it occurs frequently, please contact the EVOLVE ENERGY GROUP technician
	7	The bus voltage is unbalanced	Positive and negative bus voltage imbalance exceeds the setting threshold.	1. Check whether it can work normally after reset 2. If it occurs frequently, please contact the EVOLVE ENERGY GROUP technician
	8	DC high input voltage	DC input voltage exceeds the setting threshold.	1. Check whether the components are over matched 2. Check whether the input voltage detection circuit is normal
	9	DC low input voltage	DC input voltage is below the setting threshold.	Check whether the switch is disconnected
Other	0	Grid-connected relay failure	Relay status error	1. Check whether it can work normally after reset 2. If it occurs frequently, please contact the EVOLVE ENERGY GROUP technician
	4	Internal fan fault	Fan failure or abnormal feedback signal	1. Check whether it can work normally after reset 2. If it occurs frequently, please contact the EVOLVE ENERGY GROUP technician.

--End of the chapter--





# 6 Inverter Handling Guide

---

## 6.1 Disassemble the Inverter

Before operating, make sure that the circuit breaker between the inverter and the grid is disconnected, and the DC switch is placed in the OFF state.

- 1) Disconnect all electrical connections to the inverter, including the AC output cable, RS485 communication cable, DC input cable and PE cable.
- 2) Remove the inverter from the hanging plate.

## 6.2 Replace the Inverter

After disassembling the old inverter, if it is necessary to replace it with a new one, please follow the operation instructions in Chapter 3 and 4.

## 6.3 Package the Inverter

- If you still keep the original package of the inverter, please put it into the original package and firmly seal it with tapes.
- If you can't find the original package, please use a hard carton suitable for the weight and dimension of the inverter to firmly package it.

## 6.4 Scrap the Inverter

When the service life of the inverter expires or the inverter is replaced due to failure, it can be disposed according to the applicable electrical waste disposal laws of the place where the inverter is installed, or it can be handed over to EVOLVE ENERGY GROUP customer service personnel.

--End of the chapter--

## Warranty

If the product has any fault during the warranty period, we will provide cost-free repair or replacement service.

Any faults arising from the following reasons shall be out of the warranty:

- Users dismantle the product arbitrarily or maintain it in the wrong way;
- Out of the warranty period;
- Use the product out of the application scope stipulated in related international standard;
- Fail to install and operate the product according to the user manual;
- Use the product in improper environment;
- Use non-standard or those components/software not provided by our company;
- Damaged due to the failure of external devices;
- Any accidental damage arising from personal modification or maintenance by users.

If you need to repair the inverter due to above reasons, we will offer paid repair service after it is determined by our service department. If you need to repair or modify this product, please contact our company in advance.

## Contact US

EVOLVE ENERGY GROUP CO., LIMITED  
Address: RM 702, 7/F FU FAI COMM CTR 27 HILLIER  
ST SHEUNG WAN, HK  
Global Head Quarters 371 Sidco Industrial Estate  
Chennai 600098 India